

OLYMPUS®

ryf ag
 Ryf AG
Bettlachstrasse 2
2540 Grenchen
tel 032 654 21 00
fax 032 654 21 09
www.ryfag.ch

SZX-SDO
SZX2-STL2

INSTRUCTIONS

FOR SZX10/SZX7

SZX-SDO

SIDE-BY-SIDE VIEWING ATTACHMENT

This instruction manual is for the Olympus SZX-SDO side-by-side viewing attachment. To ensure the safety, obtain optimum performance and familiarize yourself fully with the use of this attachment, we recommend you study this manual thoroughly before operating the attachment. Retain this instruction manual in an easily accessible place near the work desk for future reference.

— This publication is printed on 100% recycled paper —



A X 7 5 0 5

CONTENTS

Correct assembly and adjustments are indispensable for the microscope to manifest its full performance. If you want to assemble the microscope by yourself, see Chapter 5, "ASSEMBLY" (pages 12 to 16) first.

IMPORTANT - Be sure to read this section for safe use of the equipment. - 1,2

1	NOMENCLATURE	3
2	CONTROLS	4-6
3	OPERATION	7-9
	3-1 Focus Adjustment.....	7
	3-2 Using the Pointer	8
	3-3 Other	9
	3-4 Photomicrography Cautions.....	9
4	SPECIFICATIONS	10,11
5	ASSEMBLY	12-16
	5-1 Assembly Diagram.....	12
	5-2 Detailed Assembly Procedures.....	13-16

IMPORTANT

The SZX-SDO is a side-by-side dual viewing attachment for use with SZX10/SZX7 microscope system. As it allows two observers to sit side by side, it is ideal for education and training purposes. Note that there are few restrictions on the installation location of this attachment.

The orientation of the images observed by the primary observer and the secondary observer is the same in both the vertical and horizontal directions. This attachment should be used in combination with the SZX2-STL2 large base.

1 Getting Ready

1. This manual pertains only to the SZX-SDO attachment. Before using this attachment in conjunction with the SZX10/SZX7 microscope and associated options, make sure that you have carefully read and understood the corresponding manuals, and that you understand how the various components of the microscopic system are used together.
2. The SZX-SDO attachment is a precision instrument. Handle it with care and avoid subjecting it to sudden or severe impact.
3. Do not use the attachment anywhere where it may be exposed to direct sunlight, high temperature and humidity, dust, or vibrations. (For operating environment conditions, see Section 4, "SPECIFICATIONS" on page 10.)
4. Before replacing the pointer illumination bulb, be sure to set the main switch to "○"(OFF), unplug the TDO power supply unit and other cords and wait until the bulb and its surroundings have fully cooled down.
5. Be sure to use only the specified tungsten bulb when replacing the pointer illumination bulb.

Applicable bulb	6V10WGE (mfd. by Hosobuchi Electric Lamp)
-----------------	---

6. Do not plug the pointer illuminator cord into any unit except the TDO power supply unit.
7. Make sure this attachment is installed in a room where there is as little vibration as possible and that the work surface on which this attachment is installed is sturdy and level (with inclination within 5°). If vibration is still noticeable, use the BH3-DMP anti-vibration pad.
8. Before placing a specimen which is sensitive to static electricity (such as a packaged circuit board) on the stage of the large base, place a conductive mat or similar object on the stage.
9. Installable modules
 - Zoom microscope body/focusing assembly: SZX2-ZB10/SZX-ZB7 and SZX-FOFH*
 - * Only the SZX-FOFH focusing assembly for heavy load can be used.
 - Base: SZX-STL2 large base (Other bases cannot be used because they cannot assure stability)
 - Observation tube: Observation tube for the primary observer: Applicable trinocular/binocular observation tube.
Observation tube for the secondary observer: Applicable binocular observation tube.
 - Intermediate attachment: SZX2-LBS (above the SZX-SDO) Note that there may be insufficient ambient light and decentration.
SZX2-ILLC10 (below the SZX-SDO)
SZX-AS (below the SZX-SDO) SZX7 only.

Safety Symbol

The following symbol is found on the attachment. Study the meaning of the symbol and always use the attachment in the safest possible manner.

Symbol	Explanation
	Before use, carefully read the instruction manual. Improper use could result in personal injury and/or damage to the equipment.

2 Maintenance and Storage

1. To clean the lenses and other glass components, simply blow dirty away using a commercially available blower and wipe gently using a piece of cleaning paper (or clean gauze).
If a lens is stained with fingerprints or oil smudges, wipe it gauze slightly moistened with commercially available absolute alcohol.
▲ Since the absolute alcohol is highly flammable, it must be handled carefully.
Be sure to keep it away from open flames or potential sources of electrical sparks – for example, electrical equipment that is being switched on or off.
Also remember to always use it only in a well-ventilated room.
2. The equipment uses plastic resins extensively in its external finish. Do not attempt to use organic solvents to clean the non-optical components of the microscope. To clean these components, use a lint-free, soft cloth lightly moistened with a diluted neutral detergent.
3. Never disassemble any part of the microscope as this could result in malfunctions or reduced performance.
4. This equipment should be disposed of by following the rules and regulations of your national or local government.

3 Caution

If the attachment is used in a manner not specified by this manual, the safety of the user may be imperiled. In addition, the attachment may also be damaged. Always operate the equipment as outlined in this instruction manual.

The following symbols are used to set off text in this instruction manual.

- ▲ : Indicates that failure to follow the instructions in the warning could result in bodily harm to the user and/or damage to equipment (including objects in the vicinity of the equipment).
- ★ : Indicates that failure to follow the instructions could result in damage to equipment.
- ◎ : Indicates commentary (for ease of operation and maintenance).

1 NOMENCLATURE

©If you have not yet completed the assembly of the microscope yet, see Chapter 5, "ASSEMBLY" (pages 12 to 16) first.

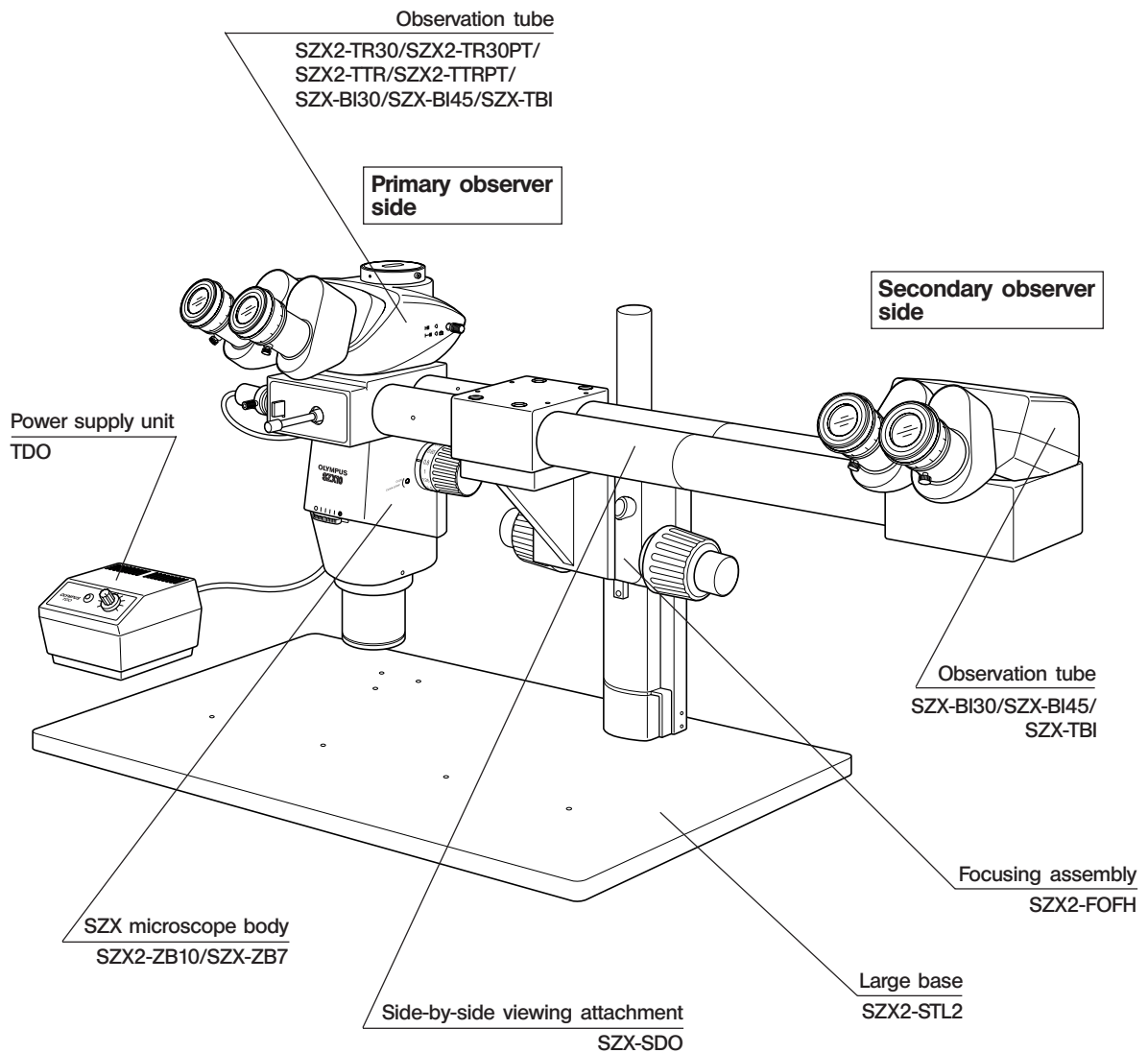

2 CONTROLS

**Side-by-side viewing attachment
SZX-SDO**

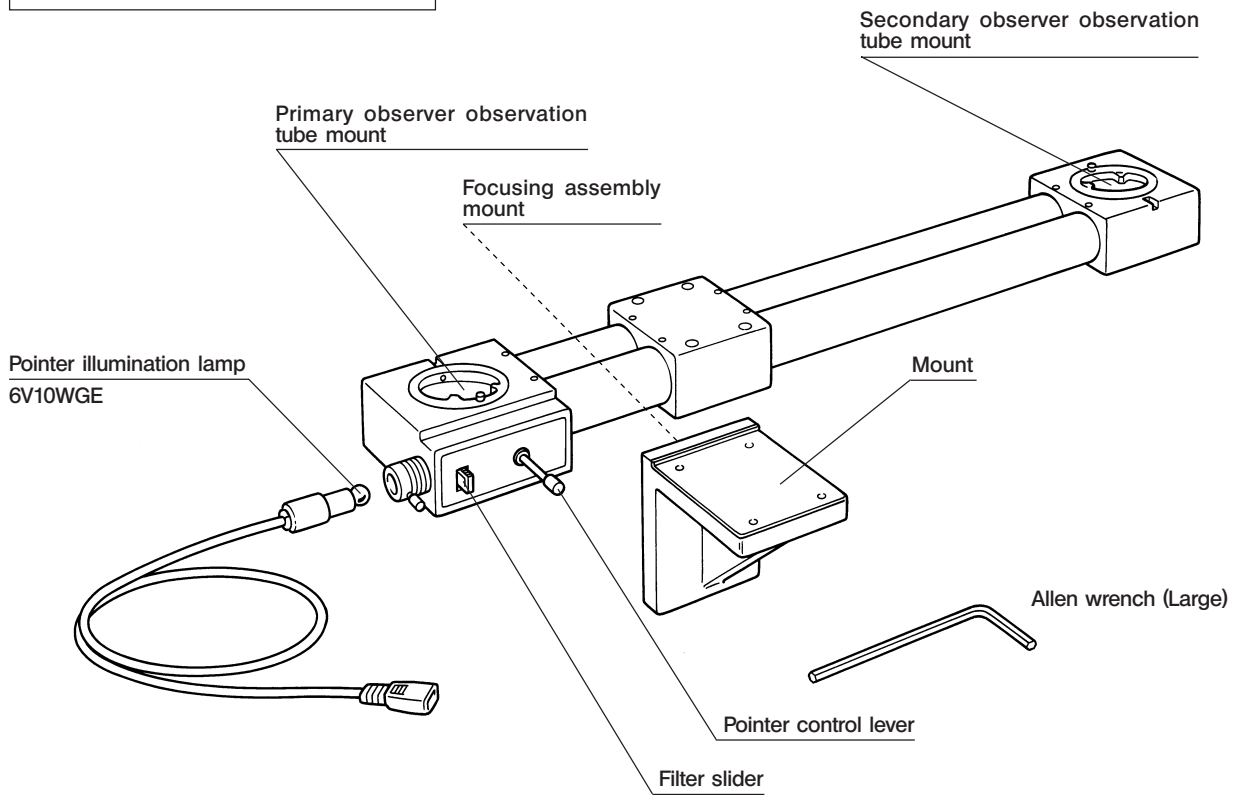

**Power supply unit
TDO**

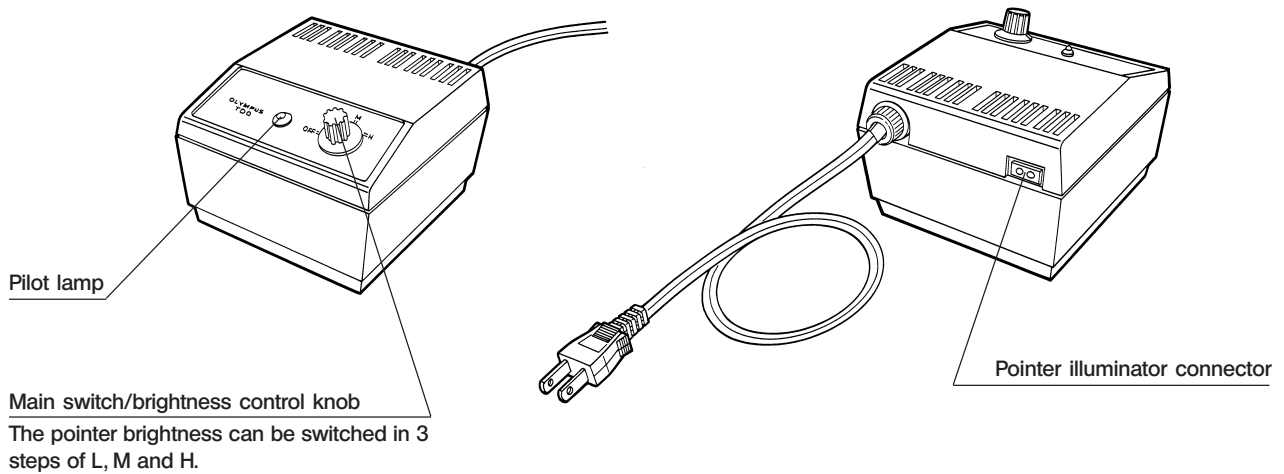

**Large base
SZX2-STL2**

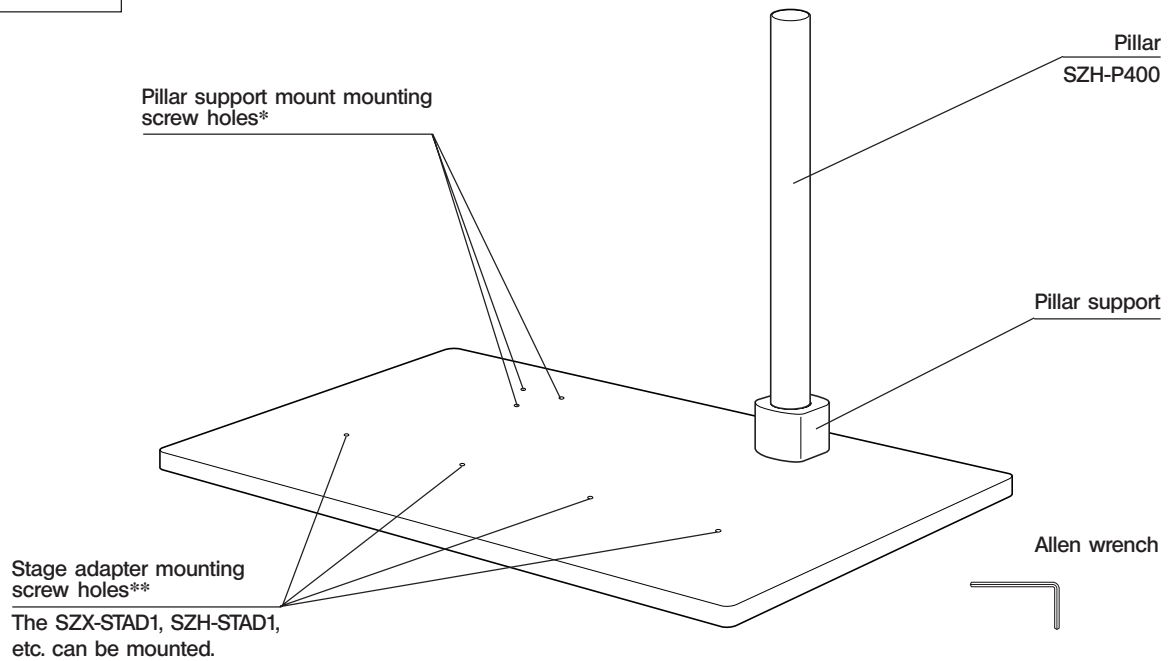

* If the pillar support is installed on the left side (using the large Allen wrench), the secondary observer can be positioned on the left side of the microscope. In this case, however, the pointer control lever is located on the rear side, interfering with operability. In addition, if a trinocular observation tube is installed on the left side, the pointer cannot be shown on a photomicrograph or TV screen.

**The SZX-STAD1 or SZH-STAD1 stage adapter, the SZX-STAD2 stage adapter (together with the SZH-P600 auxiliary pillar) or the SZ2-FO focusing stage can also be installed.

◎For transmitted light observation, the SZX2 transmitted light illumination stand (SZX2-ILLK/ILLB/ILLD) ② can be placed on the top of the base ① as shown below.

For reflected light illumination, refer to the related instruction manuals.

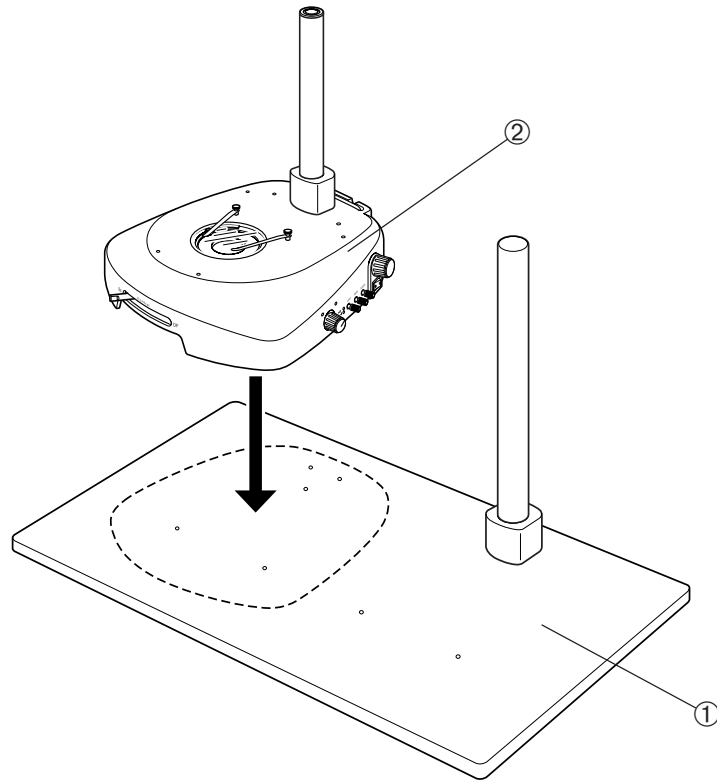

3 OPERATION

3-1 Focus Adjustment

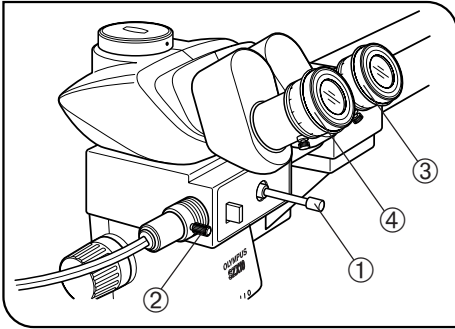

Fig. 1

1 Focusing at the Primary Observer Position (Fig. 1)

1. Set the brightness control knob on the power supply unit to "M" to light up the pointer.
 2. Look through the primary observer's eyepiece to see the pointer. If the pointer is not visible in the field of view, use the pointer control lever ① to bring it into the center of the field.
 3. Loosen the lamp socket clamping knob ② slightly. Then, while looking through the eyepiece, turn the lamp socket until the pointer is brightest, then tighten the clamping knob.
 4. Turn the right eyepiece diopter adjustment ring ③ until the pointer is in focus.
 5. Look through the right eyepiece and focus on the specimen using the coarse and fine focusing knobs on the microscope body.
 6. Turn the left eyepiece diopter adjustment ring ④ until the specimen is in focus.
- Ⓞ The pointer and the coarse and fine focus adjustment knobs can be operated only from the primary observer's side. They cannot be controlled by the secondary observer.

2 Focusing at the Secondary Observer Position

Turn the left and right eyepiece diopter adjustment rings until the specimen is in focus. (When the specimen is in focus, the pointer is also brought in focus.)

3-2 Using the Pointer

1 Pointer Brightness Adjustment

Looking through the eyepiece, set the pointer brightness by turning the brightness control knob on the power supply unit.

Indication	Application
H	Used with brightfield of view
M	Used with normal brightfield observation
L	Used with dark field of view (darkfield observation, etc.)

★ If the eyepiece incorporates micrometer disks, setting the pointer brightness to “H” while observing a dark specimen may generate a pointer ghost image.

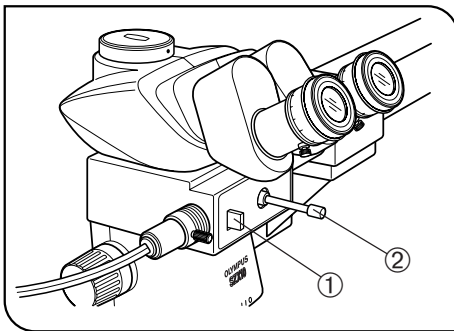

Fig. 2

2 Pointer Color Selection

(Fig. 2)

You can change the color of the pointer so that it is easily visible with specimens of different colors. Push in the filter slider ① on the rear to change the color to green and pull it out to change the color to orange.

3 Pointer Displacement

(Fig. 2)

You can move the pointer to any desired location within the field of view by moving the pointer control lever ② on the rear up, down, left or right.
 ◎ When not using the pointer, use the lever to move it outside the field of view.

3-3 Other

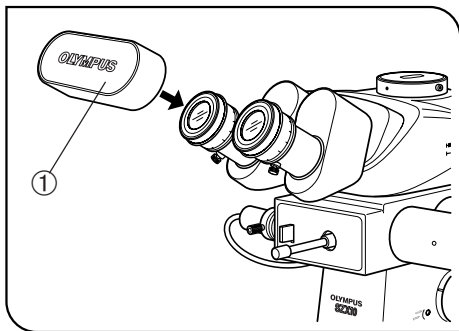

Fig. 3

1 Using the Reverse Incidence Prevention Cap

(Fig. 3)

When either the primary or secondary observation tube is not being used, be sure to put the provided reverse incidence prevention cap ① on the eyepiece to prevent penetration of reverse incident light during observation.

3-4 Photomicrography Cautions

In general, the procedure for taking photographs (including digital camera photographs) is the same as usual. This section describes special considerations that apply when taking photographs with the SZX-SDO attachment installed.

1. Provided that the primary observer's position is on the left side, you can take photographs that include the pointer using a trinocular observation tube (the SZX2-LBS should be used when using an observation tube other than a trinocular observation tube).

⊙When you use a genuine Olympus trinocular observation tube, photo eyepiece and photomicrography system, the pointer (arrow) is always focused.

2. Pointer brightness is set higher than specimen brightness to ensure adequate contrast. This has the following effects on photographs that are not apparent during visual observation.

1) Since the pointer is always overexposed when exposure is correct for the specimen, the pointer color will fade to white in color photographs.

2) When taking a photograph with a photomicrography system with automatic exposure control, the brightness of the pointer will cause the specimen to be underexposed. To prevent this, set the photomicrography system's specimen distribution compensation dial to the "OVER" position.

3) Since the effects of the pointer are greater when making long exposures of dark specimens, first check the exposure time with the pointer illumination turned off. Then, after turning the pointer illumination back on, make the exposure manually with the exposure time identified above.

3. Take photographs from the primary observer's position.

★ When taking photographs, be sure to place the reverse incidence prevention cap on the secondary observer's eyepieces.

★ To avoid reducing stability, do not install the photomicrography system/digital camera at the secondary observer position.

4 SPECIFICATIONS

■ Side-by-side viewing attachment SZX-SDO

Item		Specification
1. Distance between primary and secondary observer tubes		650 mm parallel (side by side)
2. Image orientation		Same at primary and secondary observers' positions (erect image)
3. Eyepoint height		Same at primary and secondary observers' positions
4. Intermediate attachment magnification		1X at primary and secondary observers' positions
5. Maximum field of view (mm)		22 mm dia. at primary and secondary observers' positions
6. Mounting base		Mounted on SZX2-STL2 using SZX2-FOFH. Cannot be mounted on other bases.
7. Pointer	Shape	Arrow, upward (when observed through binocular assembly)
	Colors	2 colors — Orange/Green (Switchable only by primary observer)
	Movement	Joystick. (Controllable only by primary observer)
8. Pointer power supply		TDO power supply unit (100 V, 110 – 120 V, 220 – 240 V; 50/60 Hz; 8 VA). Illumination brightness switchable in 3 steps.
9. Pointer illumination lamp		6V, 10 W tungsten bulb (6V10WGE mfd. by Hosobuchi Electric Lamp)
10. Dimensions		820(W) x 204(D) x 177(H) mm (intermediate attachment thickness 56 mm)
11. Weight		4.8 kg (10.6 lb)

■ Large base SZX2-STL2

Item		Specification
1. Base	Size	500 x 350 mm
	Pillar locations	2
2. Pillar	Height	400 mm (from base top surface)
	External diameter	32 mm dia, f7
3. Installation of stage adapter		Clamping onto base top surface using screws. Clamped at 2 locations (pillar mounting locations)
4. Dimensions		500 (W) x 350 (D) x 422 (H) mm
5. Weight		9.5 kg (20.9 lb)

■ Operating environment

<ul style="list-style-type: none"> • Indoor use. • Altitude: Max 2,000 m. • Ambient temperature: 5°C to 40°C. (41°F to 104°F) • Maximum relative humidity 80% for temperatures up to 31°C (88°F), decreasing linearly through 70% (at 34°C/93°F), 60% (at 37°C/99°F) to 50% (at 40°C/104°F). • Supply voltage fluctuation: ±10%. • Pollution degree: 2 (in accordance with IEC60664). • Installation/Overvoltage category: II (in accordance with IEC60664).

5 ASSEMBLY

5-1 Assembly Diagram

The diagram below shows how to assemble the various microscope modules. The numbers in the diagram indicate the order of assembly.

- ★ When assembling the microscope, make sure that all parts are free of dust and dirt, and avoid scratching any parts or touching the glass surfaces.
- ★ Some of the modules are very heavy. Be very careful not to drop them.

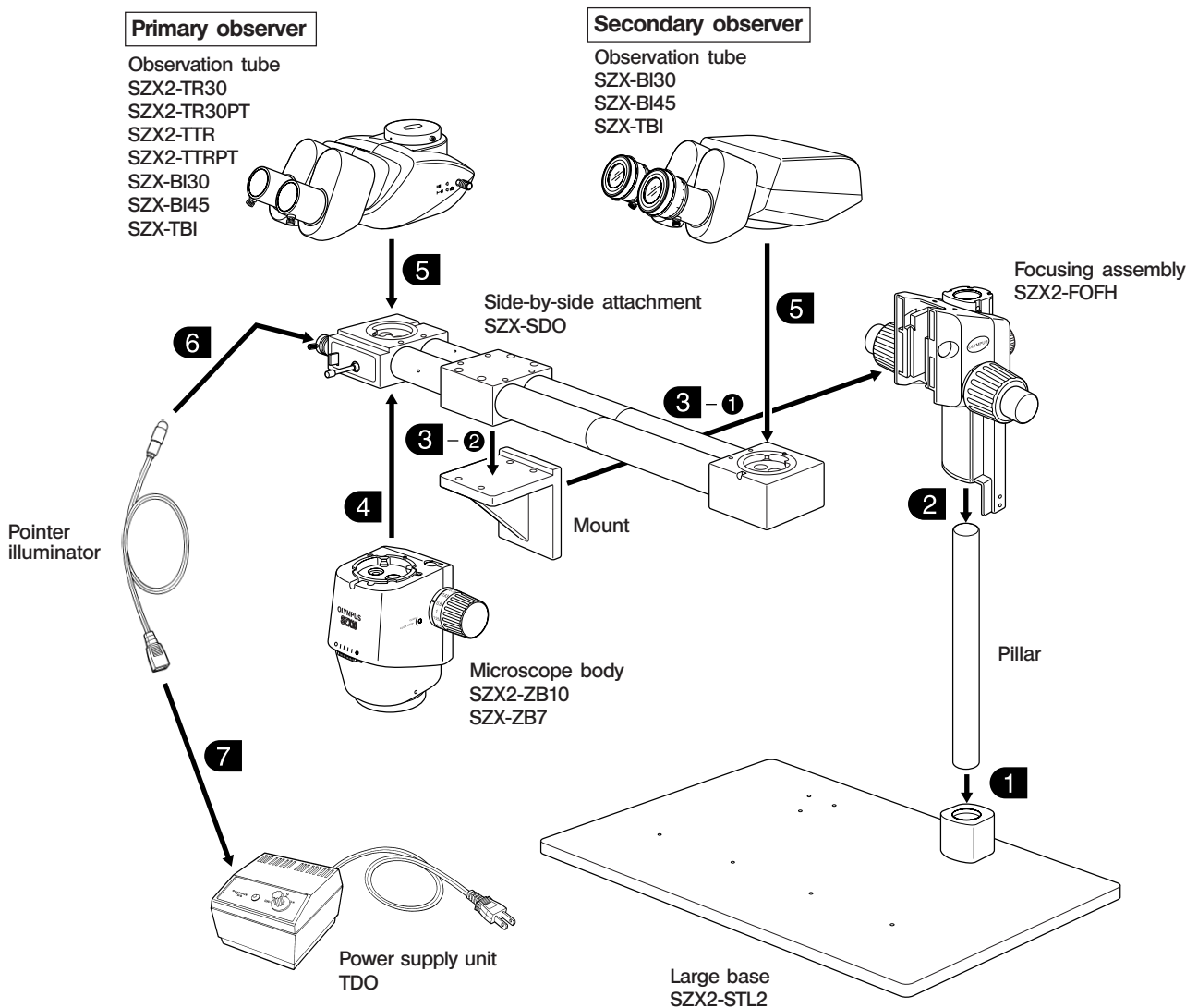

Required Tools

- Allen wrench (Large)
(Provided with the SZX-SDO)
- Allen wrench
(Provided with the large base)
- Allen screwdriver
(Provided with the microscope body)

5-2 Detailed Assembly Procedure

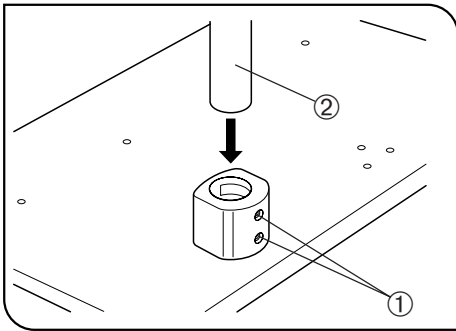

Fig. 4

1 Mounting the Pillar (Fig. 4)

⊙When the primary observer is to sit on the right side, the pillar support should be moved to the right side.

1. Using the Allen wrench provided with the base, fully loosen the 2 pillar support clamping screws ①.
2. Hold the pillar ② with the black cap up, and gently insert it into the mounting hole until it stops.
3. Using the Allen wrench, tighten the 2 clamping screws ① securely.

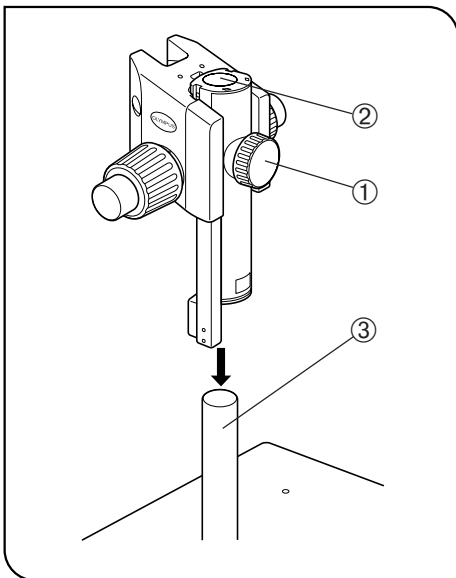

Fig. 5

2 Mounting the Focusing Assembly (Figs. 5, 6)

1. Fully loosen the focusing assembly clamping knob ①. While holding the focusing assembly with both hands, insert the pillar ③ into the mounting hole ②. (Fig. 5)

★ Insert gently without applying excessive force.

2. After inserting the focusing assembly until it reaches the stop position, secure it with the microscope body clamping knob ①. (Fig. 5)

▲ To prevent the microscope body from turning over, be sure to mount the focusing assembly so that it is located on the front as shown by “○” in Fig. 6 and clamp securely. The microscope will turn over if the focusing assembly is mounted facing the rear.

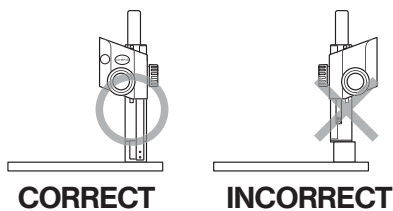

30° or less

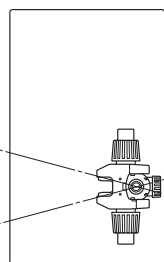

Fig. 6

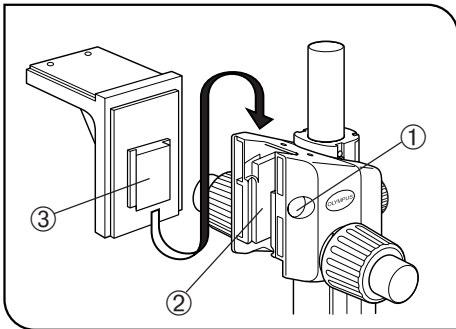

Fig. 7

3 Mounting the Side-by-Side Attachment (SZX-SDO) (Figs. 7 to 9)

1. Remove the dovetail mount clamping screw cap ① on the focusing assembly by inserting a thin object into the notch. (Fig. 7)
2. Using the provided Allen wrench, loosen the dovetail mount clamping screw inside the cap on the focusing assembly.
3. Align the dovetail mount ② on the focusing assembly with the dovetail mount ③ on the SZX-SDO side-by-side viewing attachment, and insert them gently. (Fig. 7)

★ **Do not insert them at an angle or with excessive force as this may cause malfunctions.**

4. When the side-by-side viewing attachment has been inserted until it stops, tighten the clamping screw using the Allen wrench.
5. Place the cap ① in the original position. (Fig. 7)

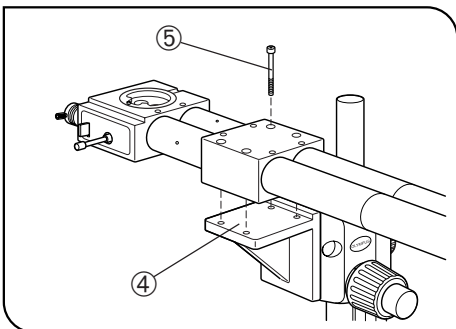

Fig. 8

6. Place the SZX-SDO side-by-side viewing attachment on the mount ④ so that the secondary observer's position is on the right side (as shown in Figure 8). Insert the 4 clamping screws ⑤ provided with the SZX-SDO attachment into the 4 screw holes and tighten using the Allen wrench (large) provided with the SZX-SDO attachment. (Fig. 8)

(If the pillar support is installed on the left side of the base, mount the attachment so that the secondary observer's position is on the left side.)

▲ **To prevent the side-by-side viewing attachment from dropping, be sure to hold it by hand until it has been clamped securely.**

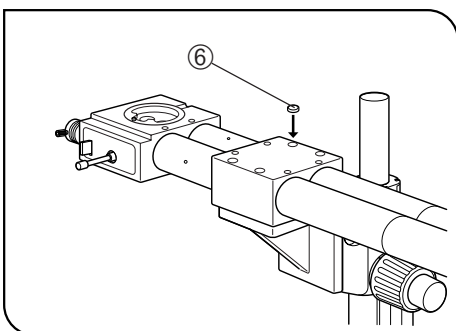

Fig. 9

7. Attach the 4 provided plastic caps ⑥ onto the 4 screw holes to hide the clamping screws. (Fig. 9)

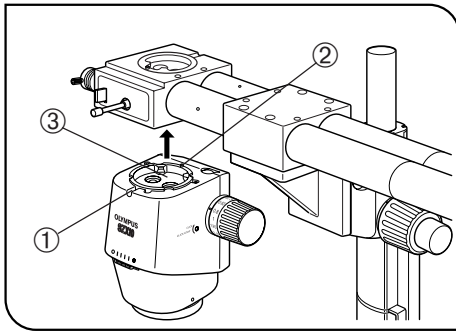

Fig. 10

4 Mounting the Microscope Body (Fig. 10)

★ Remove the objective beforehand to prevent it from being damaged by falling out during installation of the microscope body. Also be sure to hold the microscope body firmly until it has been clamped securely.

1. Using the Allen screwdriver, fully loosen the observation attachment clamping screw ① on the microscope body.
2. Align the positioning groove on the side-by-side viewing attachment with the positioning pin ② on the microscope body, and insert the dovetail mount ③ on the microscope body into the dovetail on the bottom of the attachment.
3. Using the Allen screwdriver, tighten the observation attachment clamping screw ①.

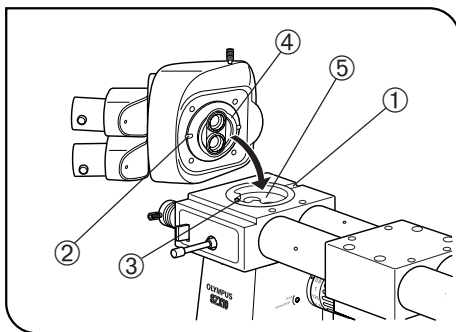

Fig. 11

5 Mounting the Observation Tubes (Fig. 11)

★ The observation tubes for the primary and secondary observers are both mounted the same way.

1. Using the Allen screwdriver, fully loosen the observation attachment clamping screw ① (on the secondary observer's observation tube, this screw is located on the front), and remove the dust cap.
2. Align the positioning groove ② on the observation tube with the positioning pin ③ on the side-by-side viewing attachment and insert the dovetail ④ on the bottom of the observation tube into the dovetail mount ⑤ of the side-by-side viewing attachment.
3. Using the Allen screwdriver, tighten the clamping screw ①.

★ Do not mount a photomicrography system or video camera on the secondary observer's observation tube by using a trinocular observation tube or the SZX2-LBS beam splitter. This will reduce stability.

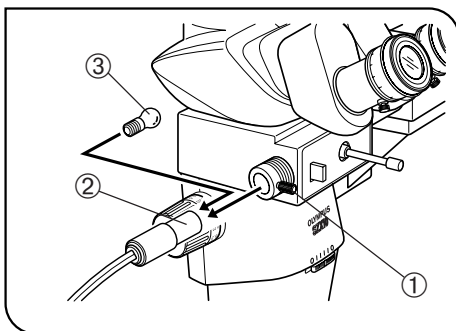

Fig. 12

6 Mounting the Pointer Illumination Bulb (Fig. 12)

1. Loosen the clamping screw ① on the lamp socket holder and remove the lamp socket ②.
2. Screw the specified bulb (6V10GE) ③ into the lamp socket.

Applicable bulb: 6V10WGE (Hosobuchi Electric Lamp)

3. Insert the lamp socket into the socket holder and tighten the clamping screw to secure it.

Bulb replacement

Before replacing the bulb, set the main switch of the TDO power supply unit to OFF, unplug the power cord and wait for the bulb to cool down.

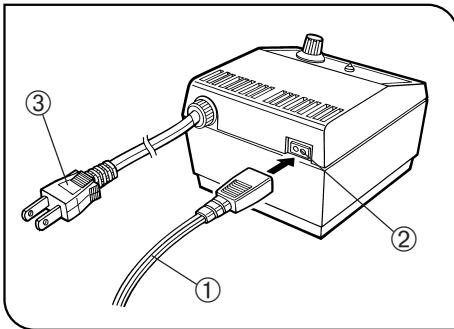

Fig. 13

7 Connecting the Power Cord

(Fig. 13)

★ Ensure that the main switch is set to OFF.

1. Insert the pointer illuminator cord ① firmly into the socket ② on the power supply unit.
2. Connect the power supply unit's power cord plug ③ to a wall outlet.

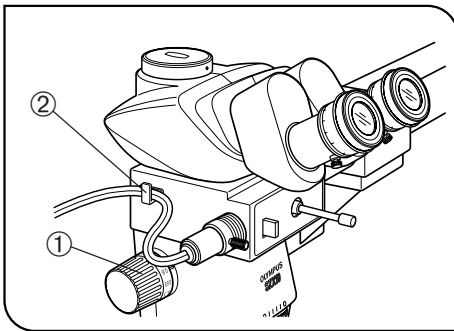

Fig. 14

8 Mounting the Cord Hook

(Fig. 14)

The pointer illuminator cord may interfere with operation if it gets entangled around the zooming handle ① on the left of the microscope body. To prevent this, attach the cord hook ② provided with the side-by-side viewing attachment to the left side or any other convenient position on the attachment and hook the cord on it.