



leica-microsystems.com

Leica E Series

Technical information

ryf ag



Ryf AG
Bettlachstrasse 2
2540 Grenchen
tel 032 654 21 00
fax 032 654 21 09

www.ryfag.ch

Leica

MICROSYSTEMS

Leica E Series – Features, specifications

Stereomicroscope	Leica ES2	Leica EZ4 10×	Leica EZ4 16×
Type of microscope	10° Greenough	10° Greenough	10° Greenough
Optical system	parfocal	parfocal	parfocal
Magnification changer	2-level, 3:1	zoom 4.4:1	zoom 4.4:1
Eyepieces for spectacle wearers	10×/20 fixed	10×/20 fixed	16×/15 fixed
Diopter correction	–	–	–
Viewing angle	60°	60°	60°
Working distance	100mm	100mm	100mm
Magnification range	10×/30×	8× to 35×	12.8× to 56×
Maximum resolution	159 Lp/mm	170 Lp/mm	170 Lp/mm
Maximum numerical aperture	0.053 nA	0.057 nA	0.057 nA
Object field diameter	20mm / 6.7mm	5.7 to 25mm	4.3 to 18.8mm
Eyecups	replaceable	replaceable	replaceable
Interpupillary distance	50 to 75mm	50 to 75mm	50 to 75mm
Beam path	100% visual	100% visual	100% visual
Focusing drive	Individually adjustable ease of movement, 75mm travel	Individually adjustable ease of movement, 75mm travel	Individually adjustable ease of movement, 75mm travel
Grip	integrated	integrated	integrated
Illumination system			
LED incident light and transmitted light	integrated, independent or combined	integrated, independent or combined, dimmable	integrated, independent or combined, dimmable
Control	On/off switch	membrane switch	membrane switch
Incident light method	angled incident light with three upper LEDs	choice of 3 methods: maximum intensity with 5 LEDs, angled incident light with LEDs, side light with 3 LEDs (patent pending)	choice of 3 methods: maximum intensity with 5 LEDs, angled incident light with LEDs, side light with 3 LEDs (patent pending)
Dimmer	–	yes, for incident and transmitted light	yes, for incident and transmitted light
Auto OFF	–	after 60 minutes	after 60 minutes
LED service life	approx. 25 000 hours	approx. 25 000 hours	approx. 25 000 hours
Light quality	homogeneous daylight, free of UV and IR	homogeneous daylight, free of UV and IR	homogeneous daylight, free of UV and IR
Maintenance	maintenance-free	maintenance-free	maintenance-free
Power supply	universal from 100V to 240V, voltage-sensitive, integrated	universal from 100V to 240V, voltage-sensitive, integrated	universal from 100V to 240V, voltage-sensitive, integrated
Digital camera			
Camera	–	–	–
Output	–	–	–
Analog video port	–	–	–
Integrated slot	–	–	–
Recording	–	–	–
Software	–	–	–
Accessories			
Measurement graticule/ stage micrometer	–	–	–
Other			
Dimensions and weights	3.82kg, 180 × 255 × 365	3.8kg, 180 × 255 × 365	3.8kg, 180 × 255 × 365
Ambient conditions, operation	+10°C to +40°C / rel. hum. to 35°C: 75% / atmospheric pressure 700 to 1060 hPa / storage: 20°C to 55°C		
Storage and transport	–20°C to + 52°C / rel. hum. 10 – 95% (non-condensing) / atmospheric pressure 500 to 1200 hPa		
Standards	CE Communauté Européenne / CSA Canadian Standards Association (USA, Canada)		

Stereomicroscope	Leica EZ4, open	Leica EZ4 D 10x
Type of microscope	10° Greenough	10° Greenough
Optical system	parfocal	parfocal
Magnification changer	zoom 4.4:1	zoom 4.4:1
Eyepieces for spectacle wearers	replaceable, fixed or adjustable: 10×/20, 16×/16, 20×/12 not suitable for spectacle wearers	10×/20 fixed
Diopter correction	from +5 to –5 (adjustable eyepieces)	–
Viewing angle	60°	60°
Working distance	100mm	100mm
Magnification range	depending on eyepieces used: 8× to 70×	8× to 35×
Maximum resolution	170 Lp/mm	170 Lp/mm
Maximum numerical aperture	0.057 nA	0.057 nA
Object field diameter	depending on eyepieces used: 3.4 to 25mm	5.7 to 25mm
Eyecups	replaceable	replaceable
Interpupillary distance	50 to 75mm	50 to 75mm
Beam path	100% visual	50% visual and 50% video/photo
Focusing drive	individually adjustable ease of movement, 75mm travel	individually adjustable ease of movement, 75mm travel
Grip	integrated	integrated
Illumination system		
LED incident light and transmitted light	integrated, independent or combined, dimnable	integrated, independent or combined, dimnable
Control	membrane switch	membrane switch
Incident light method	choice of 3 methods: maximum intensity with 5 LEDs, angled incident light with LEDs, side light with 3 LEDs (patent pending)	choice of 3 methods: maximum intensity with 5 LEDs, angled incident light with LEDs, side light with 3 LEDs (patent pending)
Dimmer	yes, for incident and transmitted light	yes, for incident and transmitted light
Auto OFF	after 60 minutes	after 60 minutes
LED service life	approx. 25 000 hours	approx. 25 000 hours
Light quality	homogeneous daylight, free of UV and IR	homogeneous daylight, free of UV and IR
Maintenance	maintenance-free	maintenance-free
Power supply	universal from 100V to 240V, voltage-sensitive, integrated	universal from 100V to 240V, voltage-sensitive, integrated
Digital camera		
Camera	optional: Leica DC150 with adapter	integrated, 3.0 megapixel CMOS
Output	–	USB 2.0
Analog video port	–	RCA, video, composite for projector, monitor, video recorder for SD (Secure Digital) cards
Integrated slot	–	integrated button for image recording
Recording	–	software for PC and MAC
Software	–	
Accessories		
Measurement graticule/ stage micrometer	for length measurements, for use with adjustable eyepieces	–
Other		
Dimensions and weights	3.64kg, 180 × 255 × 365	4.17kg, 180 × 255 × 365
Ambient conditions, operation	10°C to 40°C / rel. hum. to 35°C: 75% / atmospheric pressure 700 to 1060 hPa / storage: 20°C to 55°C	
Storage and transport	–20°C to + 52°C / rel. hum. 10 – 95% (non-condensing) / atmospheric pressure 500 to 1200 hPa	
Standards	CE Communauté Européenne / CSA Canadian Standards Association (USA, Canada)	

Leica E Series – Optical data

ES2 (10 447 202)				EZ4 (10 447 197) and EZ4 D with 10× eyepieces (10 447 200)			
Eyepieces	Position at magnification-changer	Magnification total	Object field Ø in mm	Eyepieces	Position at magnification-changer	Magnification total	Object field Ø in mm
10×/20	10	10×	20	10×/20	8	8×	25
	30	30×	6.7		10	10×	20
			12.5		12.5×	16	
			16		16×	12.5	
			20		20×	10	
			25		25×	8	
			30		30×	6.7	
			35		35×	5.7	

EZ4 with 16× eyepieces (10 447 198)				EZ4 without eyepieces (10 447 199) + eyepieces 10×/20			
Eyepieces	Position at magnification-changer	Magnification total	Object field Ø in mm	Eyepieces	Position at magnification-changer	Magnification total	Object field Ø in mm
16×/15	13	12.8×	18.8	10×/20	0.8	8×	25
	16	16×	15		1	10×	20
	20	20×	12		1.25	12.5×	16
	25	25.6×	9.4		1.6	16×	12.5
	32	32×	7.5		2	20×	10
	40	40×	6		2.5	25×	8
	50	48×	5		3	30×	6.7
	56	56×	4.3		3.5	35×	5.7

EZ4 without eyepieces (10 447 199) + eyepieces 16×/16				EZ4 without eyepieces (10 447 199) + eyepieces 20×/12			
Eyepieces	Position at magnification-changer	Magnification total	Object field Ø in mm	Eyepieces	Position at magnification-changer	Magnification total	Object field Ø in mm
16×/16	0.8	12.8×	20	20×/12	0.8	16×	15
	1	16×	16		1	20×	12
	1.25	20×	12.8		1.25	25×	9.6
	1.6	25.6×	10		1.6	32×	7.5
	2	32×	8		2	40×	6
	2.5	40×	6.4		2.5	50×	4.8
	3	48×	5.3		3	60×	4
	3.5	56×	4.6		3.5	70×	3.4

Leica E Series Assembly – diagram



Leica ES2 (10×)
10 447 202



Leica EZ4 (10×)
10 447 197



Leica EZ4 (16×)
10 447 198



Leica EZ4
10 447 199



Leica EZ4 D (10×)
10 447 200

Leica DC150 camera



Low eyepoint eyepieces:

Eyepieces, fixed:
10×/20 (10 447 281)
16×/16 (10 447 132)
20×/12 (10 447 134)

Eyepieces, adjustable:
10×/20 (10 447 282)
16×/16 (10 447 133)
20×/12 (10 447 135)

High eyepoint eyepieces:

Eyepieces, fixed:
10×/20B (10 447 278)
16×/15B (10 447 138)

Eyepieces, adjustable:
10×/20B (10 447 280)
16×/15B (10 447 139)

Leica E Series – Standard delivery

E Series stereomicroscopes

- 10 447 202 Leica ES2 with 10× eyepieces, 2 step stereomicroscope (3:1) 10× and 30× magnification, 60° eyetube angle, 100 mm working distance, high eyepoint eyepieces, integrated LED illumination for incident and transmitted light, power supply 100 – 240V
- 10 447 197 Leica EZ4 with 10× eyepieces, 4.4:1 zoom ratio, magnification from 8–35×, 60° eyetube angle, 100mm working distance, high eyepoint eyepieces, integrated LED illumination for incident and transmitted light, power supply 100 – 240V
- 10 447 198 Leica EZ4 with 16× eyepieces, 4.4:1 zoom ratio, magnification from 12.8–56×, 60° eyetube angle, 100mm working distance, high eyepoint eyepieces, integrated LED illumination for incident and transmitted light, power supply 100 – 240V
- 10 447 199 Leica EZ4 without eyepieces 4.4:1 zoom ratio, 60° eyetube angle, 100mm working distance, integrated LED illumination for incident and transmitted light, power supply 100 – 240V
- 10 447 200 Leica EZ4 D with 10× eyepieces, 4.4:1 zoom ratio, magnification from 8–35×, 60° eyetube angle, 100mm working distance, high eyepoint eyepieces, integrated CMOS camera 3.0 Megapixel, USB2, PAL/NTSC, integrated LED illumination for incident and transmitted light, power supply 100 – 240V

Eyepieces for EZ4 with open tubes

- 10 447 281 Eyepiece 10×/20, fixed, E Series
- 10 447 282 Eyepiece 10×/20, adjustable, E Series
- 10 447 132 Eyepiece 16×/16, fixed, S and E Series
- 10 447 133 Eyepiece 16×/16, adjustable, S and E Series
- 10 447 134 Eyepiece 20×/12, fixed, S and E Series
- 10 447 135 Eyepiece 20×/12, adjustable, S and E Series
- 10 447 278 Eyepiece 10×/20B, for spectacle wearers
- 10 447 280 Eyepiece 10×/20B, adjustable, for spectacle wearers
- 10 447 138 Eyepiece 16×/15B, for spectacle wearers
- 10 447 139 Eyepiece 16×/15B, adjustable, for spectacle wearers

Accessories for measurements with adjustable eyepieces

- 10 446 447 Graticule 10mm / 0.1mm, S Series
- 10 446 448 Graticule 5mm / 0.1mm, S Series
- 10 446 449 Graticule 5mm / 0.05mm
- 10 446 450 Crosshair graticule
- 10 447 000 Graticule, 100 graduations / 0.002"
- 10 447 001 Graticule, 100 graduations / 0.001"
- 10 447 002 Graticule, 150 graduations / 0.0005"
- 10 310 345 Stage micrometer 50mm, 0.1 / 0.01mm graduation
- 10 447 037 Stage micrometer 1", 0.001" graduation
- 10 447 477 Soft carrying case
- 10 447 496 Leica ETB (Educational Tool Box): Educational CD-Rom, Cleaning-Set, Poster of an E-Series-Stereomicroscope

Leica ES2 dimensions

Measurements in mm

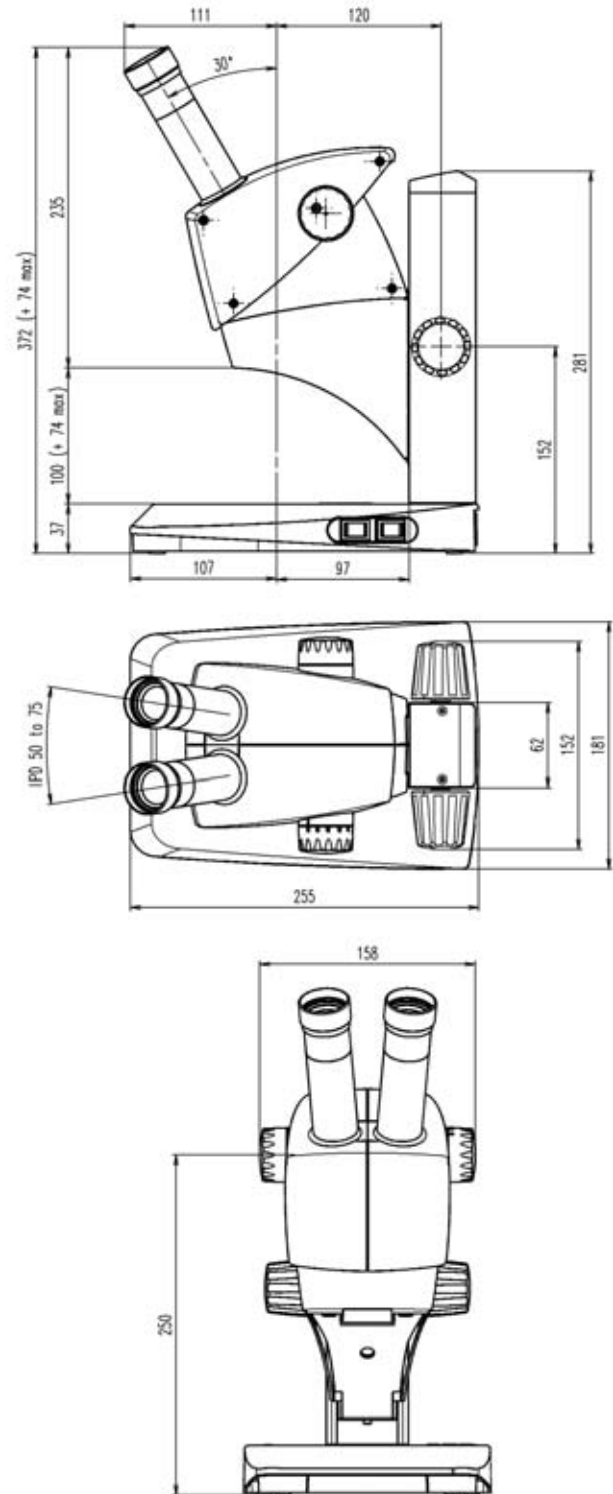

10 447 202 Leica ES2

Leica EZ4 dimensions

Measurements in mm

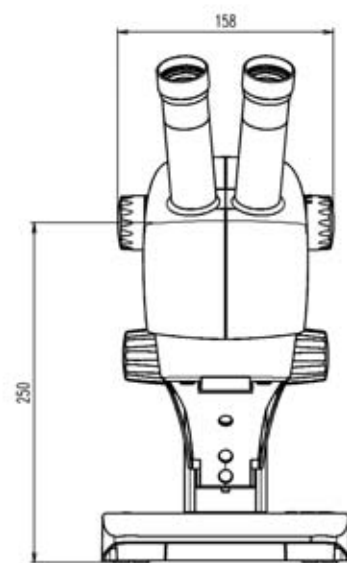
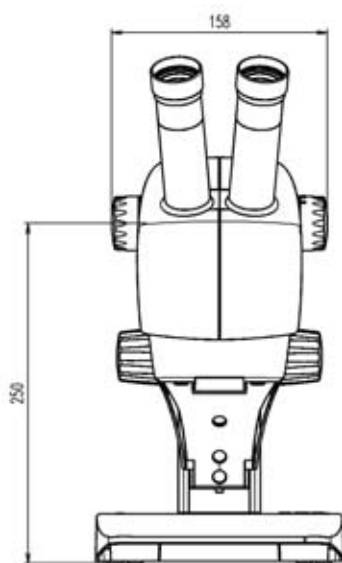
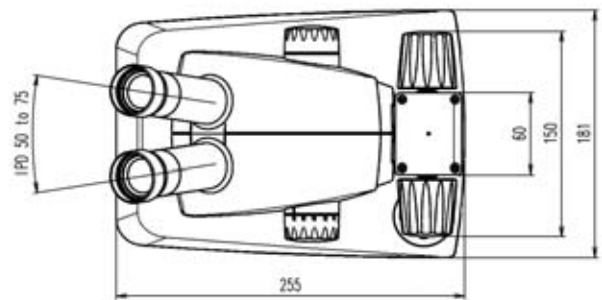
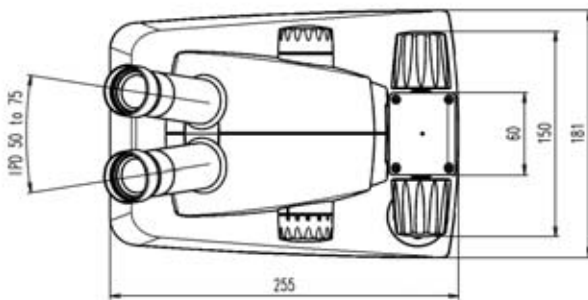
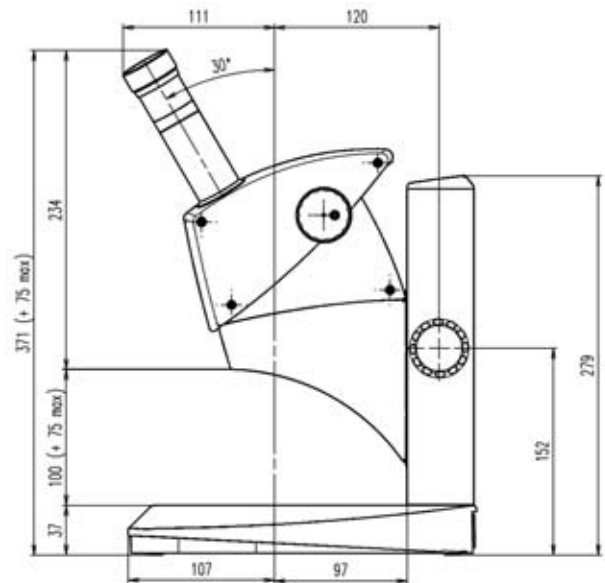
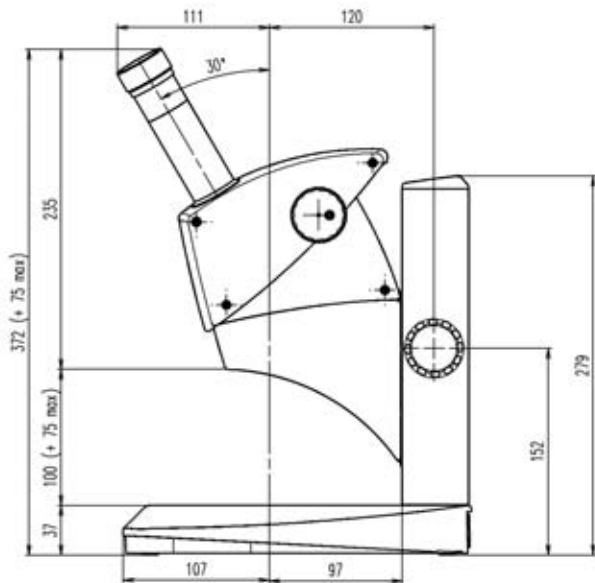

10 447 197 Leica EZ4 with 10x eyepieces

10 447 198 Leica EZ4 with 16x eyepieces

Leica EZ4 D dimensions

Measurements in mm

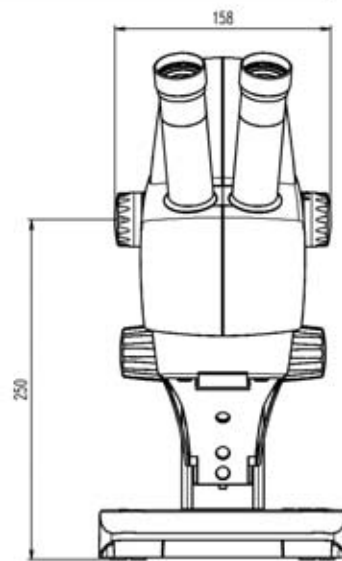
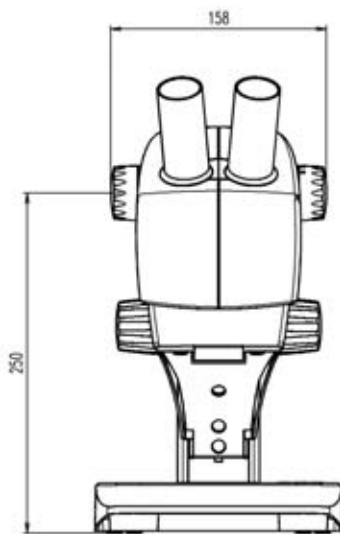
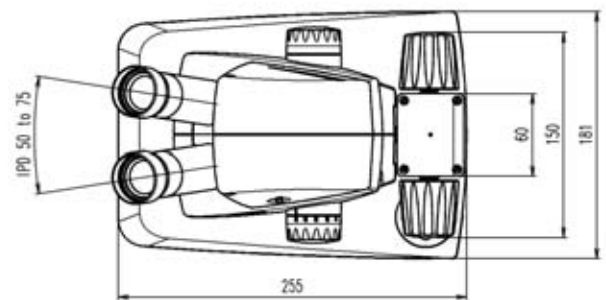
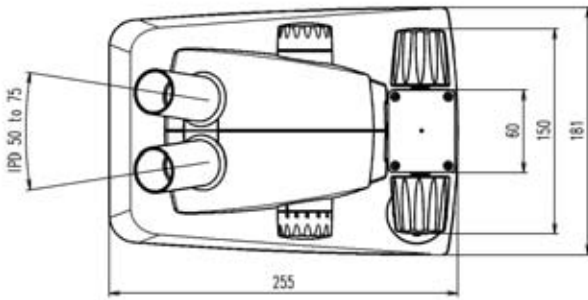
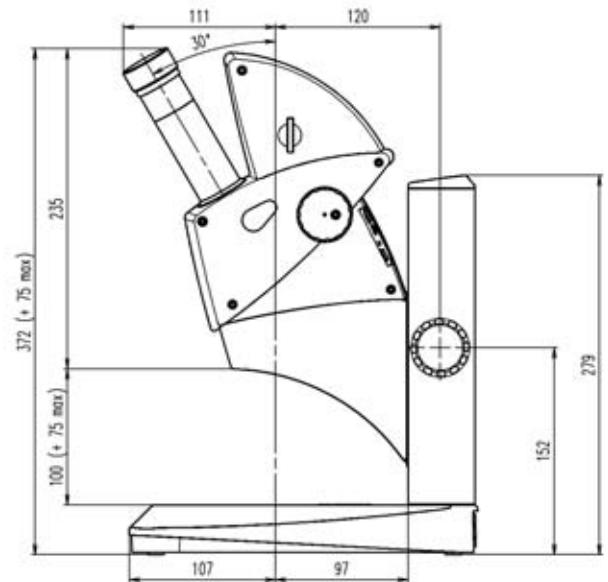
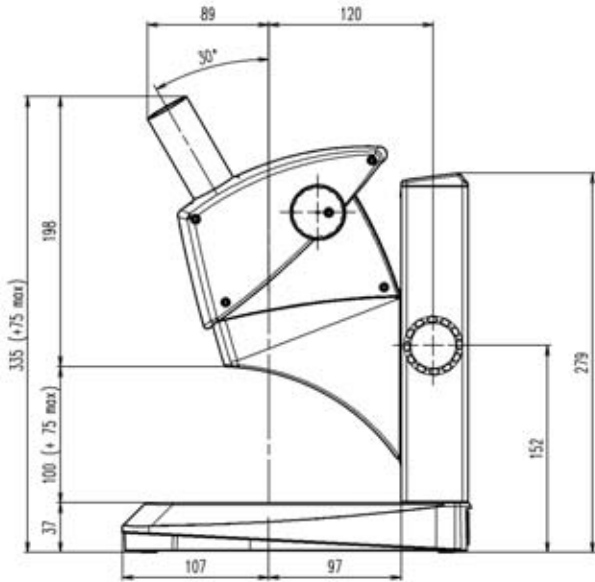

10 447 199 Leica EZ4 without eyepieces

10 447 200 Leica EZ4 D (with 10x eyepieces and integrated digital camera)

Leica Microsystems – the brand for outstanding products

Leica Microsystems' mission is to be the world's first-choice provider of innovative solutions to our customers' needs for vision, measurement and analysis of microstructures.

Leica, the leading brand for microscopes and scientific instruments, developed from five brand names, all with a long tradition: Wild, Leitz, Reichert, Jung and Cambridge Instruments. Yet Leica symbolizes innovation as well as tradition.

Leica Microsystems – an international company with a strong network of customer services

Australia:	Gladesville	Tel. +61 2 9879 9700	Fax +61 2 9817 8358
Austria:	Vienna	Tel. +43 1 486 80 50 0	Fax +43 1 486 80 50 30
Canada:	Richmond Hill/Ontario	Tel. +1 905 762 2000	Fax +1 905 762 8937
Denmark:	Herlev	Tel. +45 4454 0101	Fax +45 4454 0111
France:	Rueil-Malmaison	Tel. +33 1 47 32 85 85	Fax +33 1 47 32 85 86
Germany:	Bensheim	Tel. +49 6251 136 0	Fax +49 6251 136 155
Italy:	Milan	Tel. +39 0257 486.1	Fax +39 0257 40 3475
Japan:	Tokyo	Tel. +81 3 5421 2800	Fax +81 3 5421 2896
Korea:	Seoul	Tel. +82 2 514 65 43	Fax +82 2 514 65 48
Netherlands:	Rijswijk	Tel. +31 70 4132 100	Fax +31 70 4132 109
People's Rep. of China:	Hong Kong	Tel. +852 2564 6699	Fax +852 2564 4163
Portugal:	Lisbon	Tel. +351 21 388 9112	Fax +351 21 385 4668
Singapore		Tel. +65 6779 7823	Fax +65 6773 0628
Spain:	Barcelona	Tel. +34 93 494 95 30	Fax +34 93 494 95 32
Sweden:	Sollentuna	Tel. +46 8 625 45 45	Fax +46 8 625 45 10
Switzerland:	Glattbrugg	Tel. +41 44 809 34 34	Fax +41 44 809 34 44
United Kingdom:	Milton Keynes	Tel. +44 1908 246 246	Fax +44 1908 609 992
USA:	Bannockburn/Illinois	Tel. +1 847 405 0123	Fax +1 847 405 0164

and representatives of Leica Microsystems
in more than 100 countries.

In accordance with the ISO 9001 certificate, Leica Microsystems (Switzerland) Ltd, Business Unit Stereo & Macroscopic Systems has at its disposal a management system that meets the requirements of the international standard for quality management. In addition, production meets the requirements of the international standard ISO 14001 for environmental management.

The companies of the Leica Microsystems Group operate internationally in three business segments, where we rank with the market leaders.

• Microscopy Systems

Our expertise in microscopy is the basis for all our solutions for visualization, measurement and analysis of microstructures in life sciences and industry. With confocal laser technology and image analysis systems, we provide three-dimensional viewing facilities and offer new solutions for cytogenetics, pathology and materials sciences.

• Specimen Preparation

We provide comprehensive systems and services for clinical histo- and cytopathology applications, biomedical research and industrial quality assurance. Our product range includes instruments, systems and consumables for tissue infiltration and embedding, microtomes and cryostats as well as automated stainers and coverslippers.

• Medical Equipment

Innovative technologies in our surgical microscopes offer new therapeutic approaches in microsurgery.