

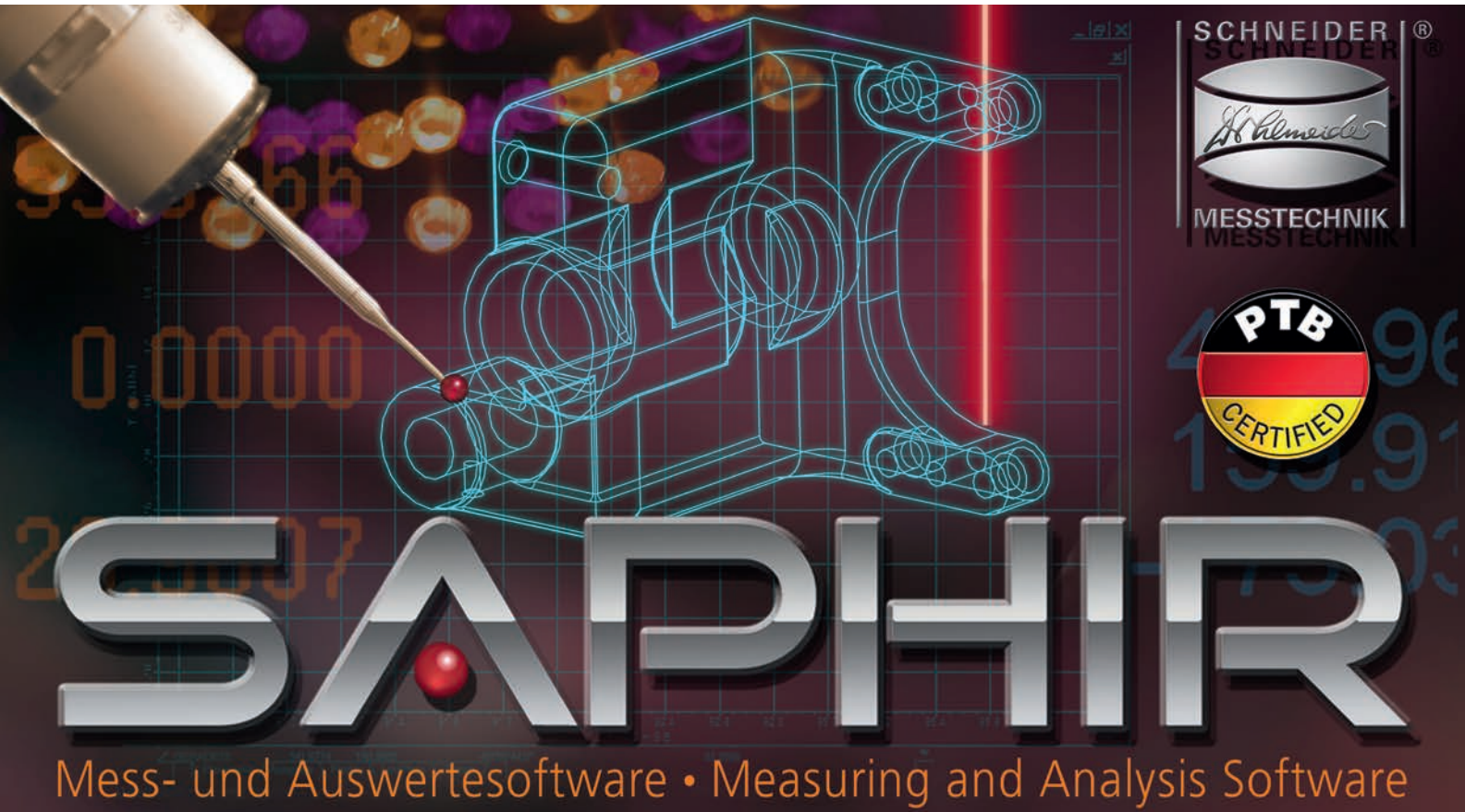

Schneider

Measurement Software



Mess- und Auswertesoftware • Measuring and Analysis Software

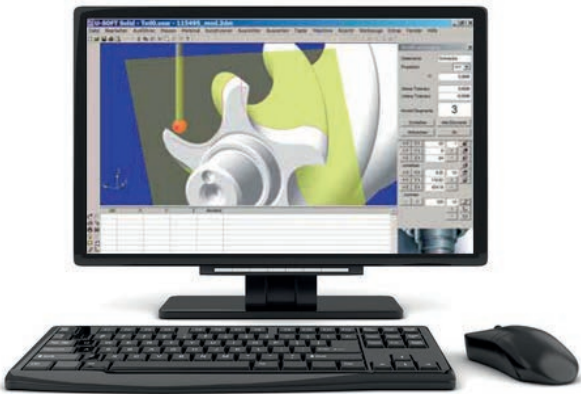

SAPHIR – 3D Measurement and Analysis Software

The smart control centre for your quality assurance



Wir machen Qualität sichtbar
Nous rendons la qualité visible
Making quality visible

ryfag.ch

MICROSCOPY + METROLOGY SERVICES

Suisse made.

RYF AG
Showroom
Bettlachstrasse 2
CH-2540 Grenschen
Tél +41 32 654 21 00
Fax +41 32 654 21 09

ryfag@ryfag.ch

RYF SA
Showroom, Sales Office
Route de Genève 9c
1291 Commugny
Tél +41 22 776 82 28
Fax +41 22 776 82 29

RYF AG (Zürich)
Sales Office
Bahnhofstrasse 17
8400 Winterthur
Tél +41 52 560 22 25
Fax +41 52 560 21 0

A powerful interface between human and machine

How can humans and their machines work together to achieve optimal results? How can manufacturers best benefit from the huge potential of information technology? This hands-on approach has guided the development of Schneider's 3D measurement and analysis software SAPHIR from the first concept to the last detail of completion. Modern manufacturing processes often involve complex geometries with tight tolerances, and long-term success in this sophisticated field is a matter of cause and effect. Therefore, nothing should be left to chance, least of all reliable measurement and data analysis. SAPHIR has all it takes to help manufacturers measure up to even the most stringent quality standards. And the name speaks for itself: SAPHIR is a true gem because it excels in measurement reliability, flexibility and adaptability. SAPHIR can be used on the entire range of multi-sensor measuring machines, workshop microscopes, optical measuring devices as well as measuring and profile projectors (optical comparators). And that's not all yet: The final "cherry on the cake" is its seamless integration into existing environments!

Since 1983, our dynamic team of expert developers has worked to anticipate ever-evolving market requirements and to tailor SAPHIR to customer needs. Thanks to the ongoing integration of new functions, SAPHIR is always prepared for the future. SAPHIR has earned a reputation for being among the world's finest products for high-precision measurement. The software, which has received certification from the German National Metrology Institute PTB, impresses with its clear architecture and user-friendly operation. Thanks to its sophisticated functions in terms of control, sensor technology and data exchange, SAPHIR is multi-sensor capable and can also manage multiple control axes.

Multi-sensor technology - a powerful cost-cutting tool

Attention to detail is crucial in the world of precision manufacturing and measurement because detail has a cumulative effect on the accuracy and thus on the quality of the whole. This is why the selection of the proper sensor is so essential for excellent work results. Schneider's 3D measurement and analysis software SAPHIR, which has been specially designed for this kind of exacting application, uniquely combines the use of a wide range of different sensors in one software package. No matter whether you wish to measure parts manufactured to loose or tight tolerances, parts with matte or glossy surfaces, light or dark parts - the sensor which best suits your measurement needs is always available. An integrated black-and-white or colour camera for measurements in incident or transmitted light, programmable multi-segment incident light illumination, a variety of touch-trigger or scanning probes (optionally equipped with an adjustable probe head allowing multi-positional inspection by means of a swivelling axis), as well as a high-precision measuring laser system will allow

you to use your measuring machine in the most targeted and efficient way. All sensors can be automatically swapped and inserted during the measuring process without having to stop or change the selected programme. SAPHIR provides one software solution for all types of sensors. It is efficient and user-friendly, allowing human attention to be focused on the measuring task at hand.



Measuring head of the PMS Series with a CCD matrix camera, a TP 200 touch probe which retracts after use and a conoscopic measuring laser.

The perfect fit!

"Rear too short", "Front too long" - those gloomy days are over for good: Thanks to the 2D and 3D BestFit feature, your measurements will always "cut a good figure". The actual measured values are optimally aligned with the 2D target values delivered in DXF formats. The best possible control of tolerances is thus guaranteed. Optionally, formats such as CATIA, AutoCAD (DWG), 3D Studio (.3ds), Lightwave (.lwo), Step (.stp, .step), Raw Triangles (.raw), STL (.stl), VDA (.vda), VRML (.vrm, .wrl), Wavefront (.obj), PDF (.pdf, .ai, .eps) as well as TXT (.txt) can be processed. The BestFit function can be applied either with the derived 2D model sections or with combined geometric primitives (basic shapes) and 3D free-form surfaces.

Paperless quality assurance

You know of it from hearsay, but have never seen it implemented? Then don't miss out on your great chance! Automated reporting ensures documented quality in each measuring operation, without the hassle of paper. The results can immediately be sent via your network to the predefined server locations, where they can be stored in the form of PDF files for further processing.

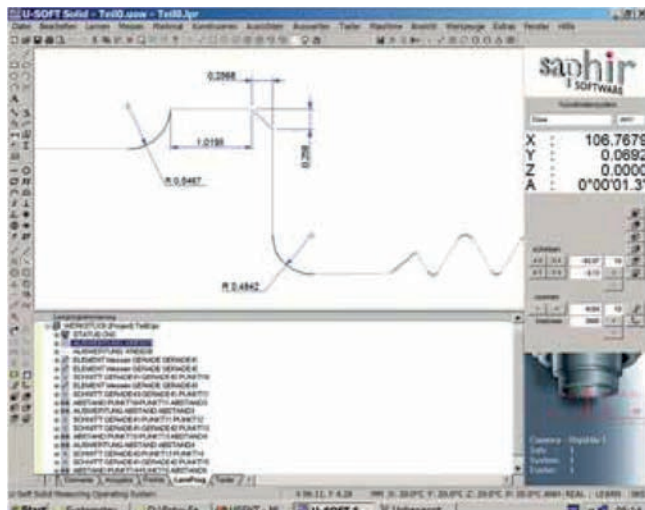

After each measuring operation, paperless and thus environmentally friendly quality documentation is provided as a PDF file or as printer (hard copy) output.

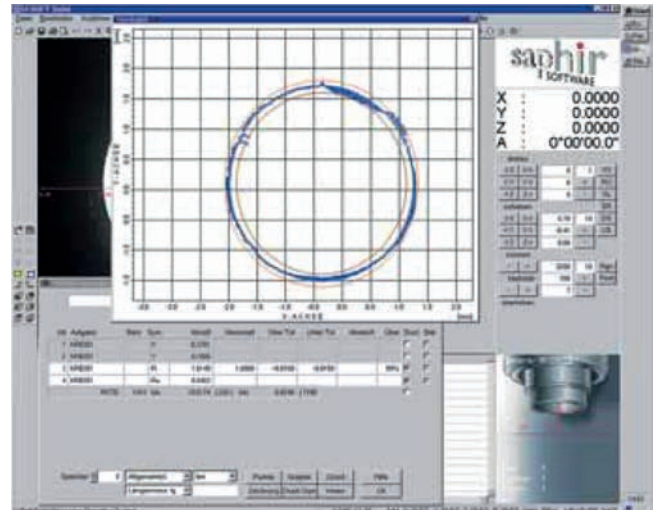

SAPHIR is focused on getting straight to the point: The position of each measuring point and its deviation from the ideal line are meticulously documented.

Automated reporting includes:

- Initial sample inspection report
- Graphic record
- Inspection record

For more detailed information, please go to:

www.dr-schneider.de

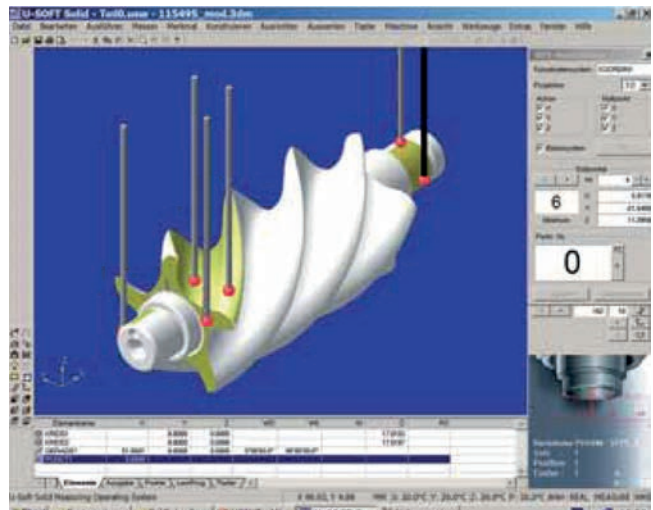

Thanks to the wide range of import formats, even complex geometries can be easily programmed.

Toolbar

The toolbar offers typically arranged functions such as "Open", "Save", "Print", "Copy" etc. that are known from other Windows applications.

Title bar

The expanded title bar displays not only the standard information, but also provides data regarding the workpiece, the working position of the sensor and the selected work mode.

Workpiece coordinate system

Spatially disoriented? - No way! One look, and you know where exactly your workpiece is positioned in relation to the measuring machine. To illustrate this feature, the 3D image and the associated 2D image are displayed merged on the screen.

Control bar

The control bar displays user-selected icons for quick access to functions, for example: Displacement of the measuring machine's arm by mouse control, virtual workpiece illumination, freely selectable workpiece views, or whatever parameters you consider important to speed up your workflow.

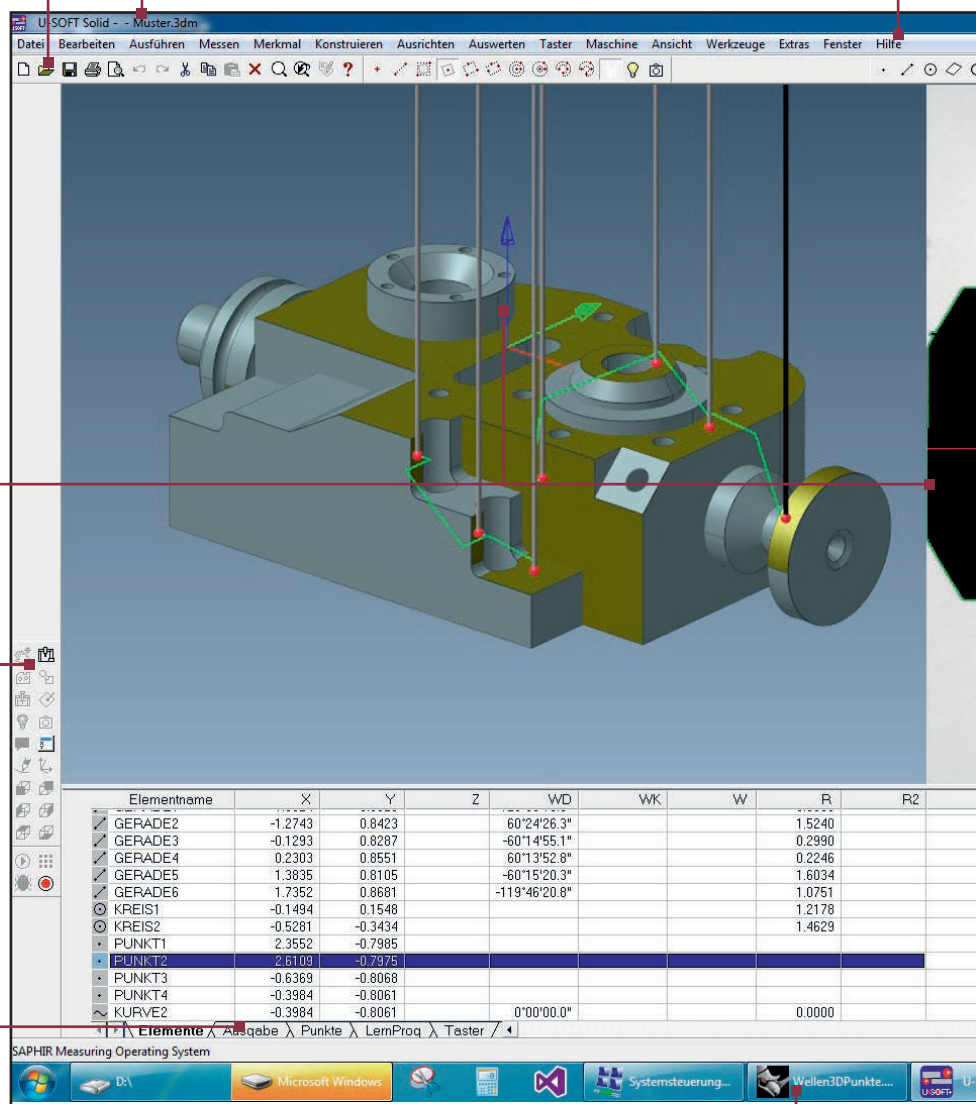

Index bar

The index bar contains the tabs relevant for the respective programme status. They include:

- Elements - display of all measured geometrical elements in list form
- Output - set of measurement records
- Points - for each element to be measured, a list of associated probing points is displayed.
- LearnProg (teach-in function) - during manual measurement, the appropriate programme is automatically recorded for future use.
- Probe - This function displays a list of all calibrated probes and associated stylus data

Menu bar

SAPHIR offers several menus allowing access to essential programme functions. Selections on the various pull-down menus provide access to even more functions.

Viewing area (viewport)

2D or 3D representation of the workpiece or measuring process, depending on the selected active probe.

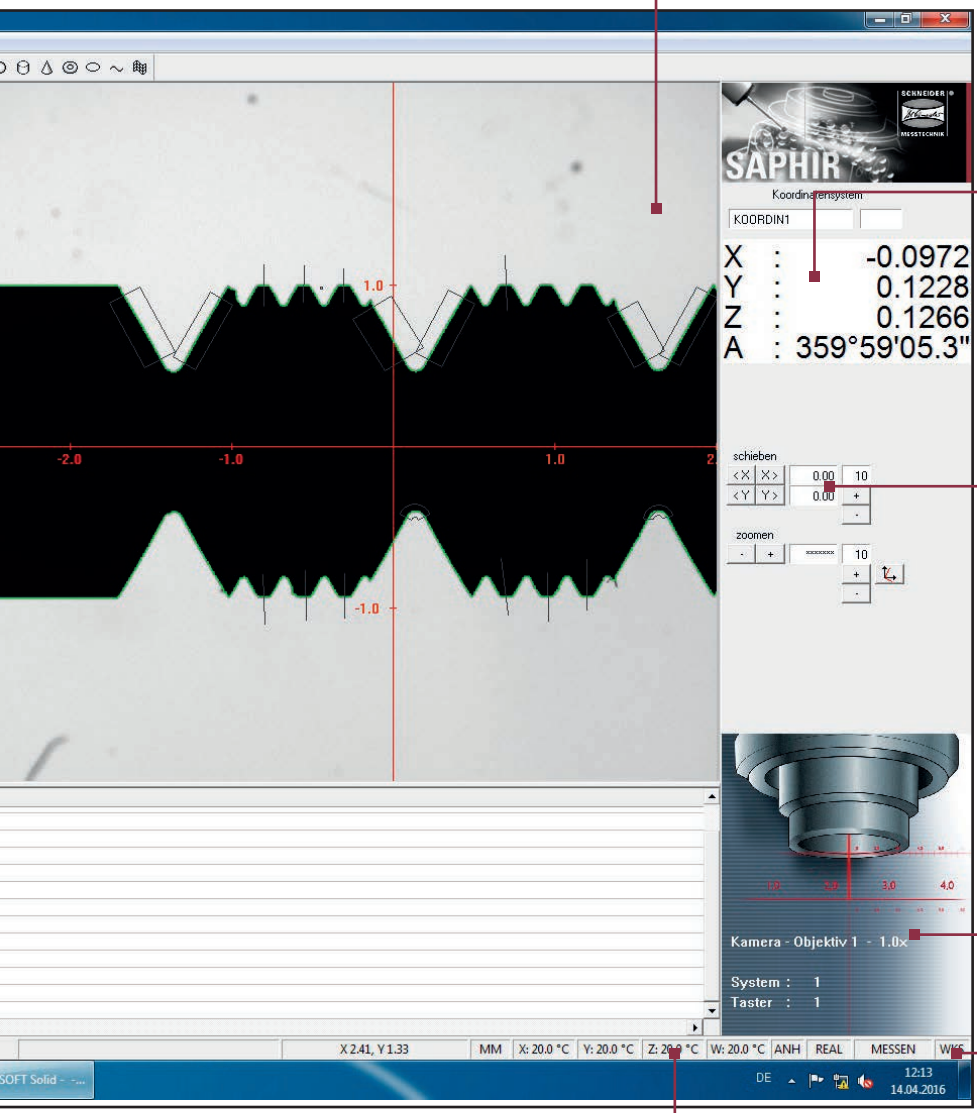

Position display

Information about the current probe position in up to 5 axis.

Virtual workpiece position

Toolbar button or mouse click: The choice is yours when it comes to moving the workpiece. Use the right-hand mouse button to rotate the workpiece, the left-hand mouse button to push it in a linear direction, and press both mouse buttons to zoom in.

Probe information

Just one look, and all relevant parameters associated with the active probe, the stylus used and the probe configuration.

Temperature compensation

If your measuring machine is equipped with a temperature compensation feature, the current values will be displayed here.

Status bar

Clear display of current programme status.

Task bar

SAPHIR is, of course, capable of multi-tasking. Use the task bar to change to another opened programme at any time.

Travelling unknown paths ...

... may be a risky venture, but not so for SAPHIR:
The 3D measuring software automatically recognises and scans not only known, but also unknown contours. 2D contours are scanned by means of a camera, 3D contours with a scanning probe - a powerful tool that is complemented by 2D and 3D BestFit features.

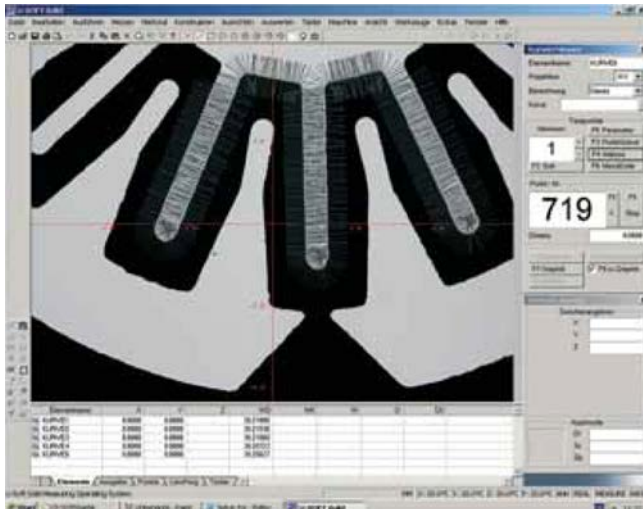

Fast, precise and accurate in all circumstances: Thanks to the contour recognition feature, workpiece dimensions can be scanned and dimensioned even without a drawing.

Fast familiarisation with the measuring software SAPHIR thanks to shopfloor-oriented measuring

- Results are available in only a few steps
- Intuitive operator guidance facilitates familiarisation with the software
- Automatic measuring of unknown contours
- Automatic recognition of circles and straight lines
- Clearly structured user interface for convenient measurement
- Fast generation of automatic measuring programmes
- No previous programming knowledge is required to create programmes
- Measuring programmes are displayed in plain text tree format
- Macros, sub-programmes as well as loop programming features facilitate programme compilation for continuous measurement tasks
- All elements can be represented graphically; individual elements can be linked up with each other so that new, composite elements can be constructed
- Graphic record

Multi-axis control with SAPHIR

Central control is the key to success in measurement, and only simultaneous control of the different axes of a coordinate measuring machine allows path-optimised programme configuration.

Schneider's measuring software SAPHIR therefore not only handles multi-axis control, but also mathematically incorporates all measuring points into the measuring process. For universal and thus even more flexible use of the measuring machine, it is also possible to provide SAPHIR with an integrated rotary and / or tilting axis besides the three coordinate axes.

The RPS (Room Positioning System) alignment function allows you to identify the position of workpieces with no or only few regular (standard) geometries. Thanks to predefined measuring points that are correlated with the 3D model as accurately as possible, the workpiece afterwards has the same coordinate system as the model.

Reference points can also be assigned from a great distance: The reference point of an assembly unit or of a final assembled product can thus be located at a distance of 1, 2, 5 m or even more.

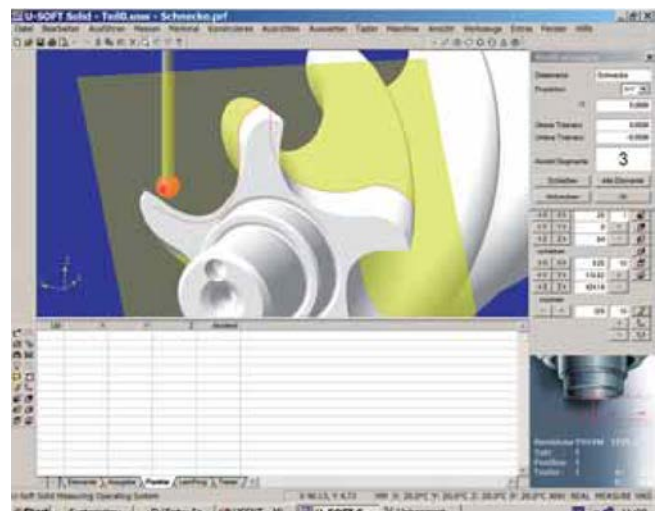

No matter how complex your workpiece may be, the 5-axis control system will detect every measuring point.

Dynamic alignment of the rotary axis

The path of the identified workpiece axis is accurately followed taking into account spatial orientation so that the edge of the workpiece always remains in the camera's field of view. Thanks to this unique feature, highly accurate and precise measurements (form and position) can be performed without tedious workpiece clamping. Even one-sided clamping of the workpiece with a jaw chuck still ensures repeatable and precise measurement results.

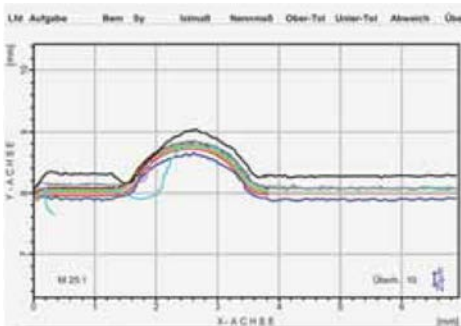

On-the-fly contour measurement

Together with the rotary axis dynamic alignment feature described above, this "on the fly" function constitutes the heart and soul of high-quality tool measurement: While the workpiece is being rotated, its maximum contour value is determined in relation to its axis by means of a dynamic measuring process. Any errors associated with the workpiece fixture are subtracted by the rotary axis dynamic alignment function.

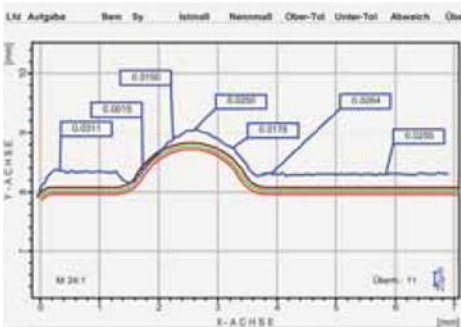

Measurement of cutting edges (optional)

A real "cutting-edge" tool in many ways! During the rotating movement of the workpiece, its cutting edge is automatically detected and identified so that the user can benefit from the full range of 3D information associated with it. Thanks to the virtual cross-section along a plane, the user obtains a cutting contour equal to that resulting from the actual milling process.

Let's take the example of a reamer:

When a cylinder is subjected to a dynamic measurement process, its cutting edge is automatically detected and identified along the way.

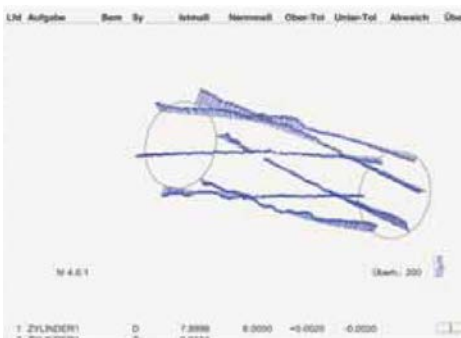

And now the example of a form cutter:

Measurement in this case is based on a DXF file that describes the contour of the cutter. The measurement process is dynamic and includes automatic cutting edge detection and identification.

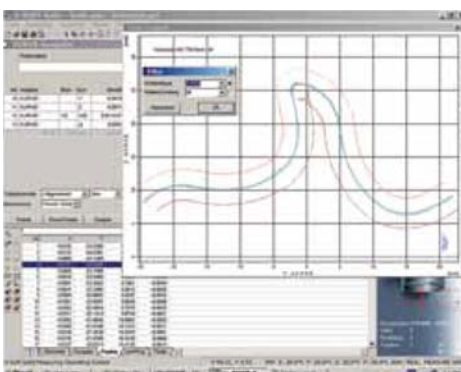
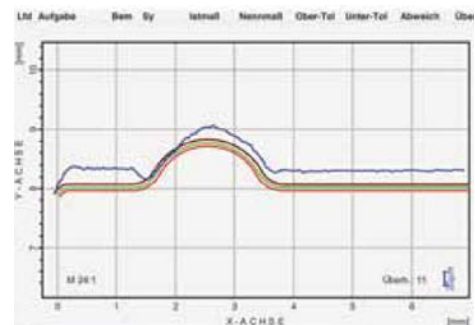

Offline programming with SAPHIR

Programming times = machine downtimes? This equation no longer holds. Thanks to the offline programming option, you can now compile programmes in your office without even considering the issue of machine downtimes.

Programme compilation does not interfere with normal machine operation. Thanks to the offline programming feature, you can take your time and create programmes right from your desk, without any costly machine downtime.

The resulting programmes are then loaded onto the respective machine from where they can be directly opened and started via your network. Especially when it comes to measuring complex 2D contours and / or 3D models, investment in this type of programming pays off in no time. The import of DXF and IGES files facilitates the comparison of measured values with the corresponding 2D target values. Should an error have crept in somewhere along the way, it will be detected and corrected very fast via the integrated simulation mode option. The file formats of this powerful software tool can be individually tailored to suit your needs.

Network-enabled and compatible - a true gem

Windows is one of today's most widely used operation systems. The SAPHIR measuring software puts this benefit to use in a unique way. In addition, it is fully network-enabled and easily communicates with CAD systems. The interfaces required for these systems are all included in the SAPHIR standard version.

Software Characteristics

Standard features

- Compatible with WIN7 and WIN10
- Element linkage and construction of composite elements*, also at the graphical level
- Input of theoretical elements
- Intersections (polygon)
- Integrated CAD functions
- Flexible configuration of inspection records
- First sample test report
- 2D DXF data import/export
- Graphic record
- Graphical representation of elements*
- Automatic vertex generation
- Administration of measuring sensors such as optics, laser system, touch-trigger and scanning probes
- Spatial alignment
- Axial alignment
- Rotary axis dynamic alignment feature with probe and optics (the workpiece always remains in the camera's field of view)
- Form and position tolerances
- Pitch measurement
- Macro and sub-programme technology
- Loops, conditional jumps and variables
- Integrated tolerance table
- Programme simulation
- Probe calibration with readout of calibration quality
- Eight different image processing probes
- Debug and editing functions for programme optimisation
- Coordinate system memory - classification of local and global systems

Optional features

- SAPHIR shaft
- User administration
- 2D digitisation and BestFit function
- 3D digitisation and BestFit function
- 3D data import
- Barcode interface
- Statistics export designer
- Mobile process analysis (MPA)
- Parameter programming
- Cam/frequency analysis and evaluation
- Rolling analysis and evaluation (crankshaft)
- CONFORMITY in compliance with 21 CFR Part 11 of the FDA (Food and Drug Administration)
- CAD import: CATIA, AutoCAD (DWG), 3D Studio (.3ds), Lightwave (.lwo), Step (.stp, .step), Raw Triangles (.raw), STL (.stl), VDA (.vda), VRML (.vrm, .wrl), Wavefront (.obj), PDF (.pdf, .ai, .eps) as well as TXT (.txt)



Wir machen Qualität sichtbar
Nous rendons la qualité visible
Making quality visible

ryfag.ch

MICROSCOPY + METROLOGY SERVICES

Suisse made.

RYF AG
Showroom
Bettlachstrasse 2
CH-2540 Grenchen
Tel +41 32 654 21 00
Fax +41 32 654 21 09

ryfag@ryfag.ch

RYF SA
Showroom, Sales Office
Route de Genève 9c
1291 Commugny
Tél +41 22 776 82 28
Fax +41 22 776 82 29

RYF AG (Zürich)
Sales Office
Bahnhofstrasse 17
8400 Winterthur
Tél +41 52 560 22 25
Fax +41 52 560 21 0