



ryf ag
ryf

Video measuring systems NEXIV VMF-K series



VIDEO MEASURING SYSTEMS
NEXIV VMF-K Series
Confocal Model

A high-end video measuring system that can perform two-dimensional measurement and highly accurate height measurement simultaneously.

NEXIV VMF-K Series

The NEXIV VMF-K series can perform two-dimensional measurement using brightfield images, as well as full-field height measurement using confocal optics. Special samples that are difficult to detect with brightfield measurements can be clearly calculated with confocal measurements. Compared to previous models, the VMF-K series has achieved faster measurements, a wider range of target applications, and superior equipment operation efficiency.



Two-in-one device for two-dimensional and height measurement

Two-dimensional and height measurement can be performed with a VMF-K series. Operators do not need to learn how to operate multiple measuring instruments, reducing the workload for measurement and equipment management.

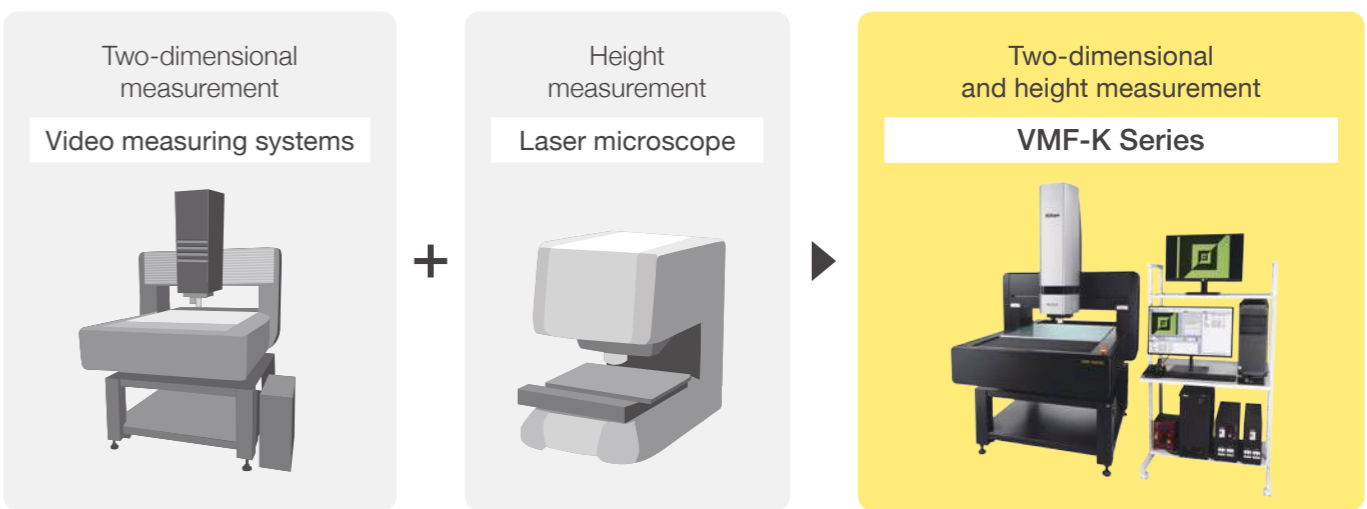

Equipped with two optical systems for two-dimensional and height measurement

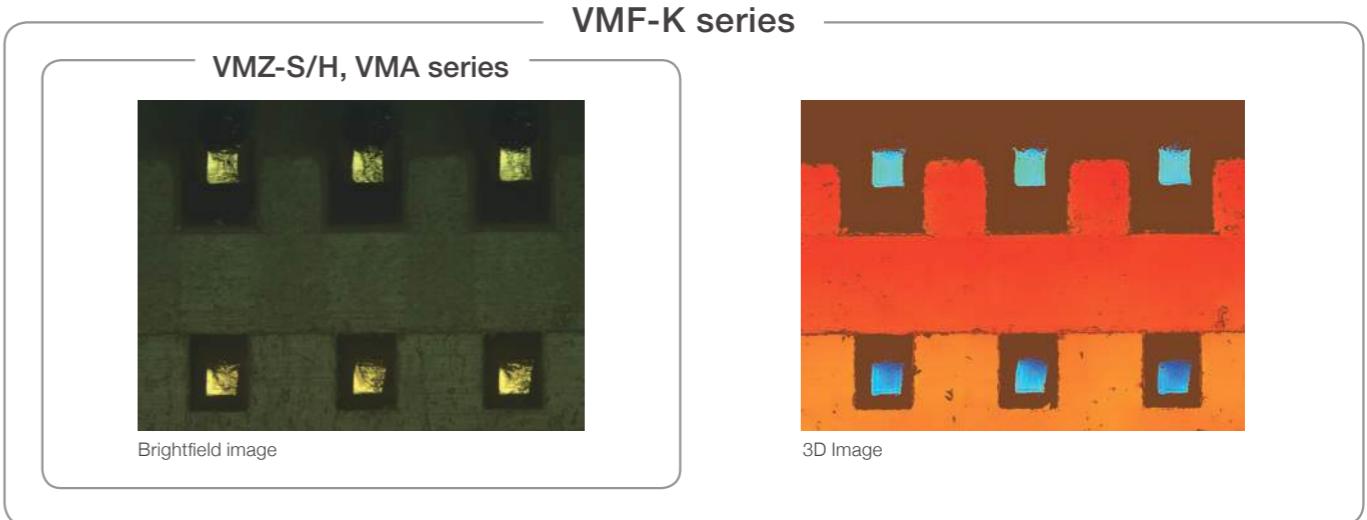

Measurement examples

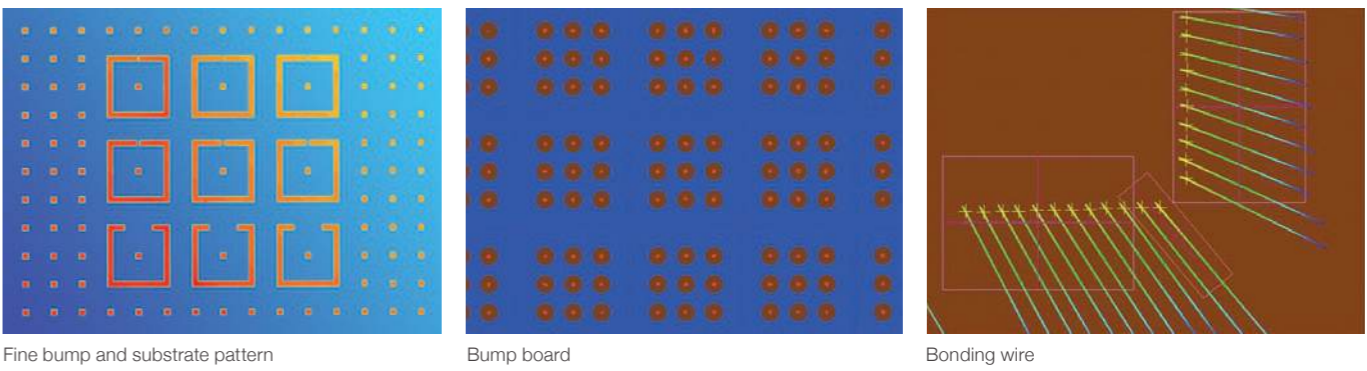

Faster and more accurate two-dimensional and height measurements

The VMZ-K series, the flagship model of NEXIV series, has evolved further while retaining highly accurate two-dimensional and height measurement.

Enhanced measurement throughput

By increasing the scanning speed in the height direction, the measurement throughput has been improved by approximately 1.5 times compared to previous model.

Comparison of measurement throughput (example)*



*This is a comparison of measurement throughput based on our specified measurement conditions. The improvement of measurement throughput varies depending on the measurement content.

Additional 45x model to support fine processing

To meet the demands of measuring the fine dimensions of cutting-edge semiconductor devices that are becoming increasingly miniaturized and highly integrated, the 45x high-magnification model has been added to the standard lineup. Multi-dimensional details less than 2 μm can be measured quickly and with high accuracy. Thereby, meeting the needs for measuring precision semiconductor packaging.

Measurement items of Redistribution Layer (RDL)

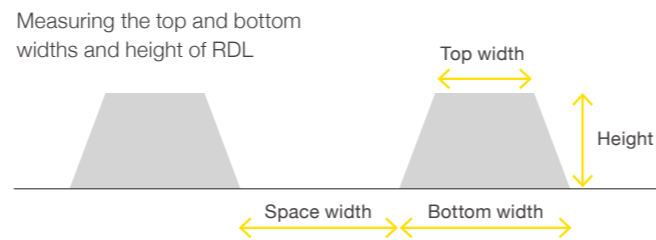

2.0 μm L/S height image (bird's-eye view)

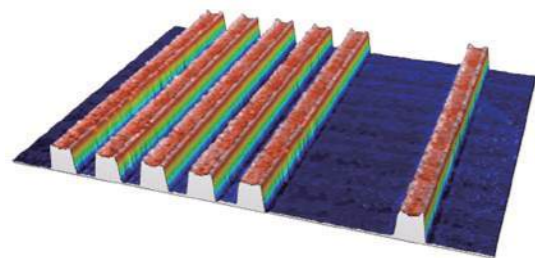

1.5 μm L/S height image (bird's-eye view)

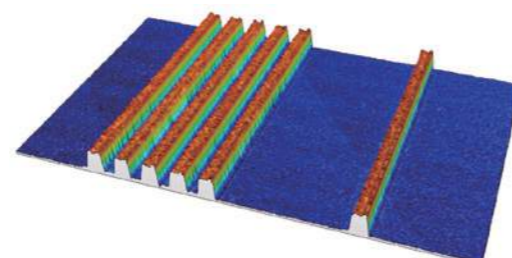

*Obtained using MountainsMap® X (optional)

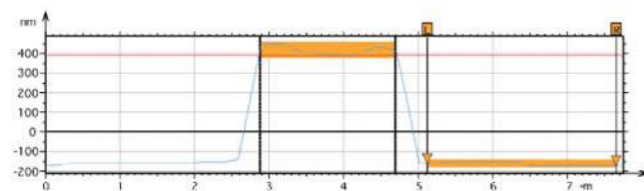

Profile picture

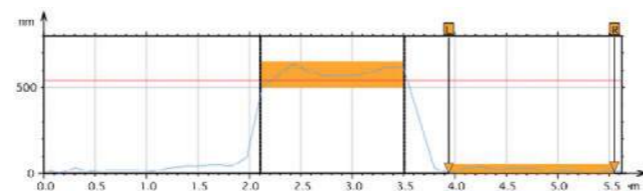

Profile picture

Superior equipment operation efficiency

● Confocal light source LED

The confocal light source used in previous models was Xenon, but has been upgraded to LED. The light source lifespan has increased by approximately 10 times, improving the equipment's operating rate and reducing the burden of lamp replacement and disposal.

● LED indicator to show device status

Each measuring head is equipped with a colored LED indicator to display device status. The light sequence can be set from the dimensional measurement software NEXIV AdvancedMeasure.

*Signal tower option is also available.



● Improved maintenance

In addition to a completely new exterior design, the measurement head cover is easier to attach and remove. General operation and maintenance will be easier as interior access is improved and the number of parts that require maintenance is reduced.

Supports highly accurate, high-speed coordinate system measurement

Another major feature of video measuring systems is the ability to measure coordinate systems over long dimensions that exceed the field of view. Nikon's NEXIV series reflects the technology and knowledge it has accumulated over many years as a manufacturer of video measuring systems in its system design, enabling highly accurate and stable measurements, even over long dimensions.

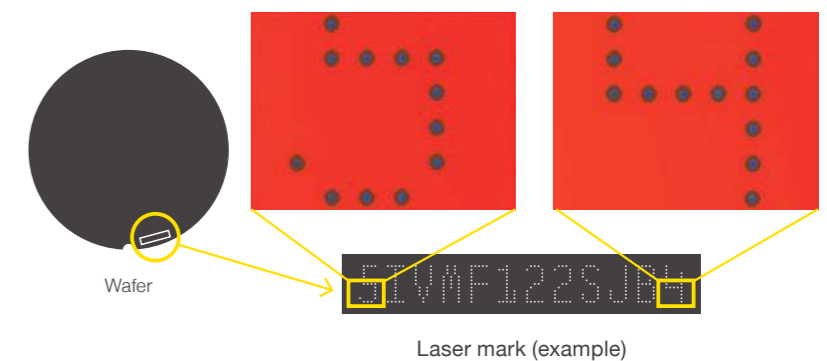

● Hardware structure that achieves highly accurate measurements

The effects of environmental temperature changes are minimized as the main body guide rails and measurement stage are made from similar thermal expansion coefficient materials. This reduces the risk of deformity and inaccurate measurements.

● In-house linear encoder boasts highest resolution levels

Nikon's in-house developed linear encoder has a resolution of 0.01 μm – the highest level for video measuring systems. Included on all axes as standard, this precisely detects linear position to provide highly accurate and stable measurement results.

STRENGTHS

3D imaging for full-field measurement

As it is possible to perform 2D/height measurement all within the field of view, the NEXIV VMF-K series achieves overwhelming measurement throughput compared to using brightfield images.

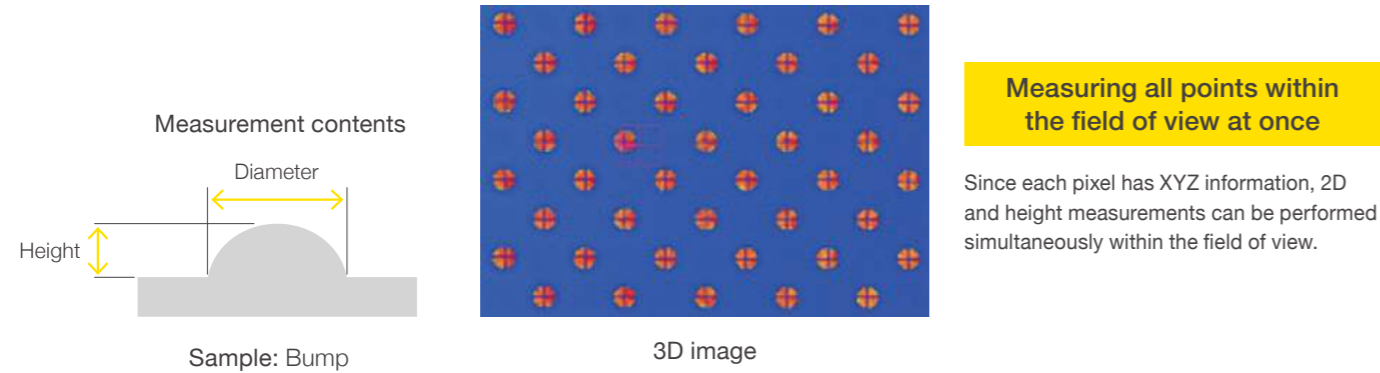

Supports samples with high contrast and unstable light reflection

Accurate measurement of high contrast samples tends to be difficult with brightfield illumination because their edges appear unclear. Confocal optics provide a clear display, and facilitate accurate detection of sample edges.

High contrast sample (copper wire on print board etc.)

Confocal observation accurately captures the shape, even for samples that are difficult to measure accurately in brightfield, due to effects such as halation.

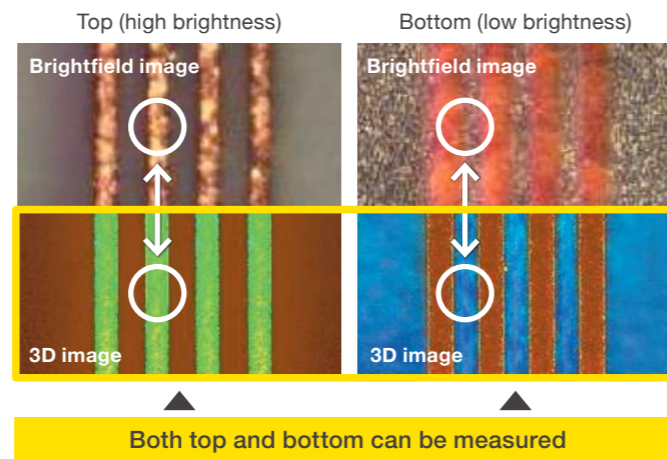
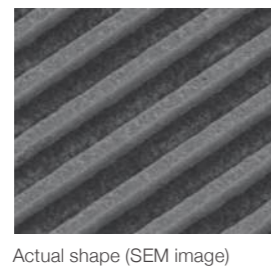

Highly transparent and thin samples (metal surface films, semiconductor resists, etc.)

For transparent samples with unstable light reflection, confocal observation can accurately detect two points: the transparent surface and the metal surface.

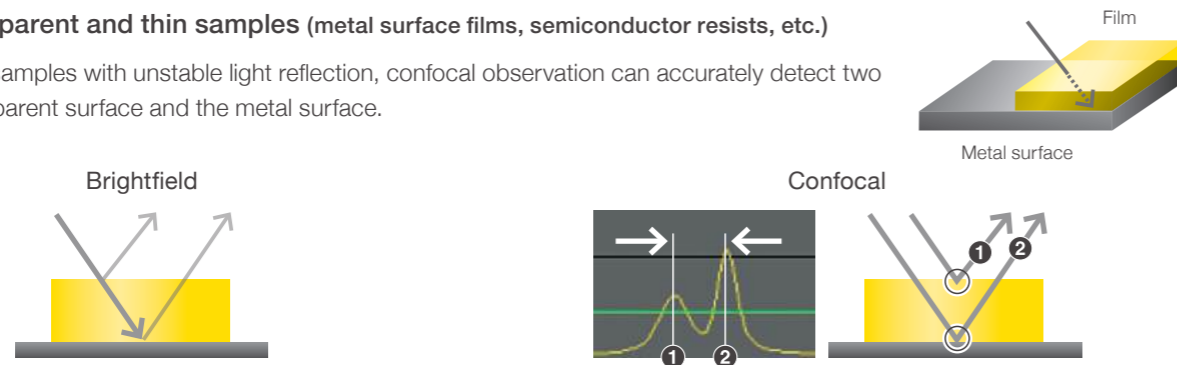

Unstable reflection makes it difficult to detect the exact location

Both the top and bottom heights can be detected accurately.

MECHANISM

Constructing 3D images using confocal optical systems

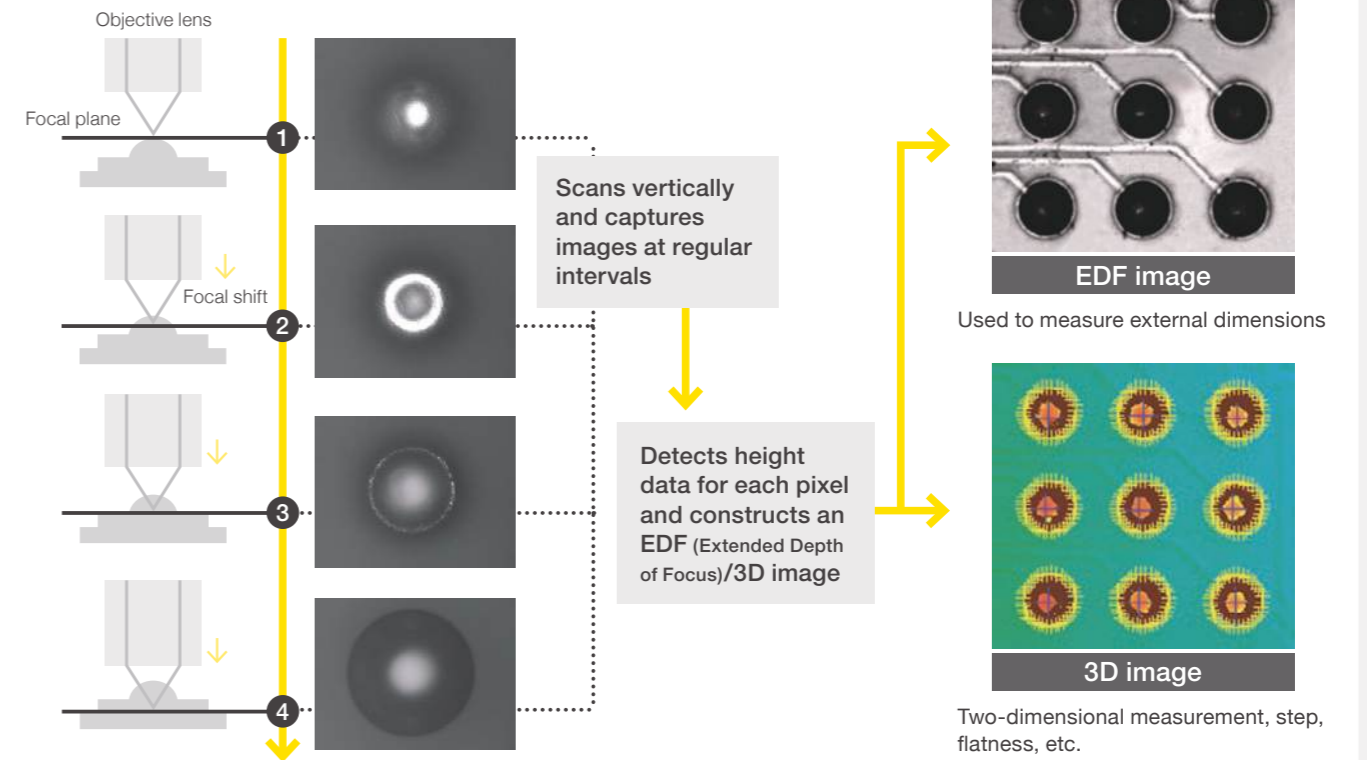

Nikon's Confocal model NEXIV uses the Nipkow disk method

Confocal optics is an optical technology that uses pinholes to block light outside the focal plane, achieving high resolution and high contrast. The confocal optics of the VMF-K series uses the Nipkow disk method. The Nipkow disk has pinholes arranged in a spiral shape. By shining light on the disk while rotating it, a confocal image of the entire focal plane is obtained. Multiple confocal images are created by moving the optical system alongside to construct an image with height information.

The Nipkow disk enables extremely high-speed imaging, but requires advanced design and manufacturing technologies to precisely control the high-speed rotating disk.

Nikon developed video measuring systems equipped with a Nipkow disk type confocal optical system in the early 2000s, and has continued innovating ever since, helping customers around the world.

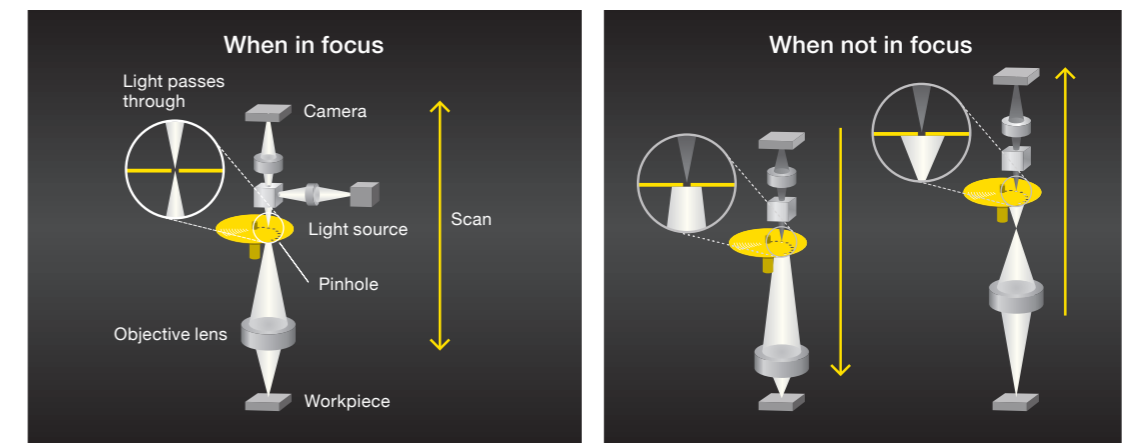

Confocal optical system (Nipkow disk method)

APPLICATIONS

Fine bump and substrate pattern

A combination of 2D measurement with 15x zoom brightfield image and height measurement with 3D image enables diverse measurements.

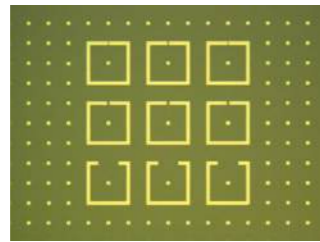

Brightfield image (minimum magnification)

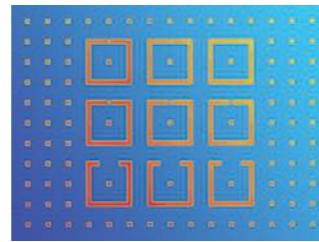

3D image

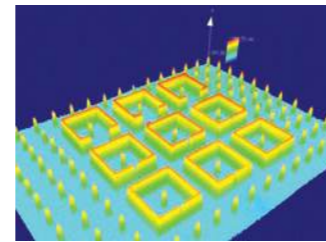

Bird's-eye view image by EDF/Stitching Express (optional)

Probe cards

The XY coordinates (centre of gravity/centre of square) and Z coordinates (average/highest point) of the microscopic contact parts of the probe card are measured simultaneously within the field of view.

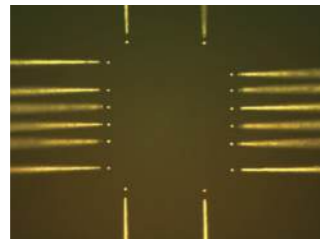

Brightfield image

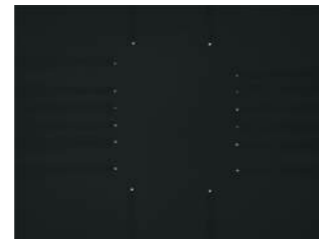
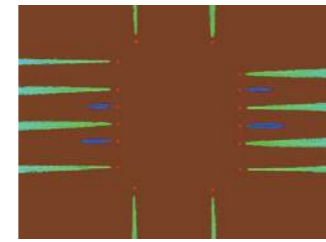

Image taken with confocal optics, with the tip in focus



3D image

Wafer level packages

The positions and diameters of bumps, vias, chips, etc. can be inspected at high speed by full-field height measurement.

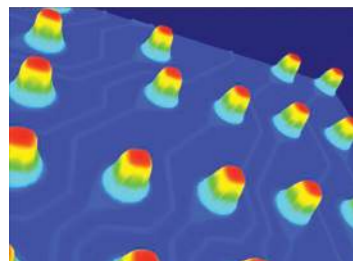

Bird's-eye view image by EDF/Stitching Express (optional)

Laser mark

In addition to the full length of the text beyond the field of view, the depth of the engraved laser mark can be controlled with 3D images.

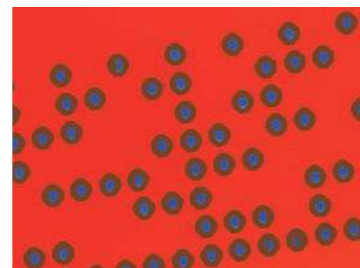

Bonding wire loop height

The 3D image detects the highest points of all wires within the field of view at once. The wire shape can also be confirmed from the height profile information.

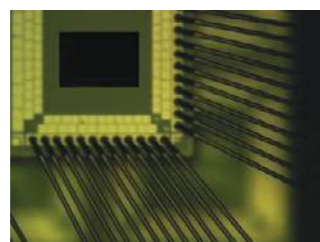

Brightfield image

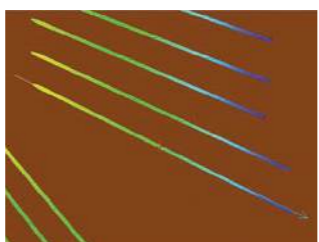

3D image

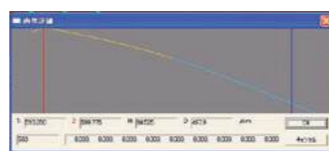

Display of wire height profile

SOFTWARE

A sophisticated GUI builds on the expertise gained from the NEXIV series and ensures efficient measurement and evaluation of three-dimensional shapes.

Measurement program creation and replay

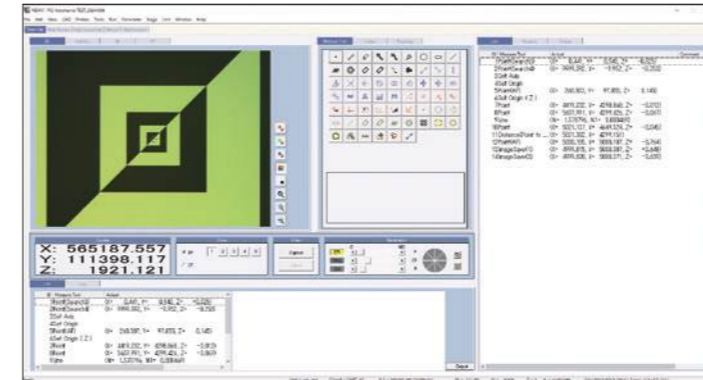

- Both 2D measurement of brightfield images and height measurement of 3D images are possible in the same field of view, at high speeds and with high accuracy.
- In addition to the measurement tools employed by the NEXIV series, 3D feature measurement tools are available for diverse workpiece shapes, such as ball/flat bumps, bonding wires, and probe card pins. The optimized algorithms for measurement sequence enable simultaneous measurement of multiple points in the field of view.
- Measurement results are stored as CSV format.

User-friendly operations enhance the efficiency of semiconductor wafer and PCB chip measurements.

Map recipe creation

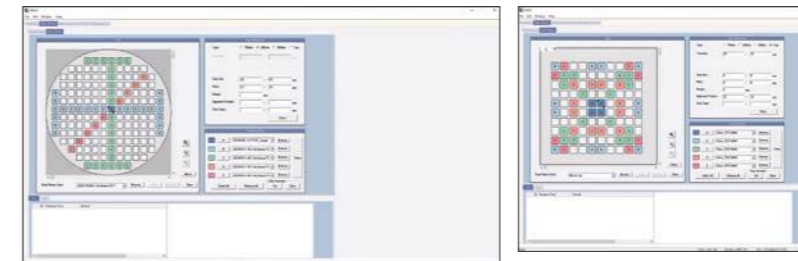

Wafer

PCB chip map

- Supports wafer and tray measurement. Simply input the chip size and chip pitch to easily create a map recipe and measure any chip on the map.

Map measurement execution

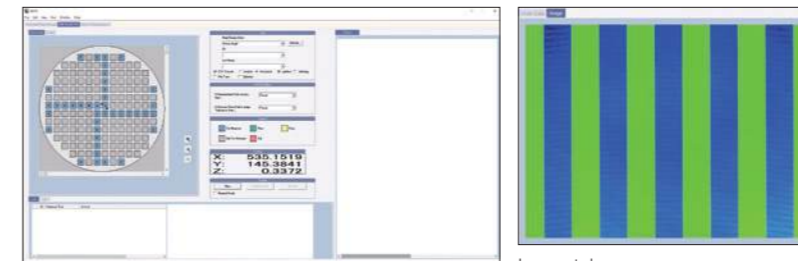
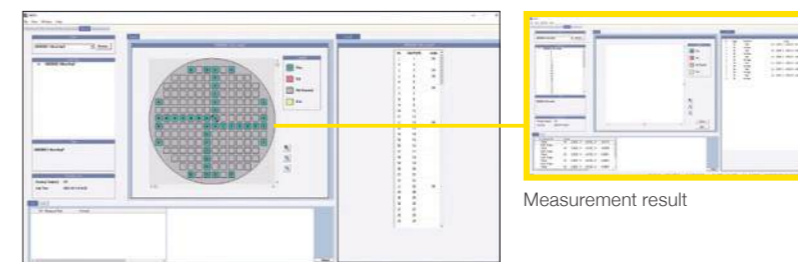

Image tab

- A specified chip can be easily measured by inputting map recipe file, ID, and lot number.
- The workpiece being measured can be viewed by changing to the image tab.

Measurement result review



Measurement result

- The accept/reject status of every chip can be graphically reviewed on the map.
- A result screen is shown when a chip is selected, making it easy to verify each chip's measurement.

USAGE TIPS

Use as a high-precision review measurement device

By using the coordinates of abnormal points acquired by other measuring instruments, the NEXIV VMF-K series can easily deliver highly accurate review measurements.

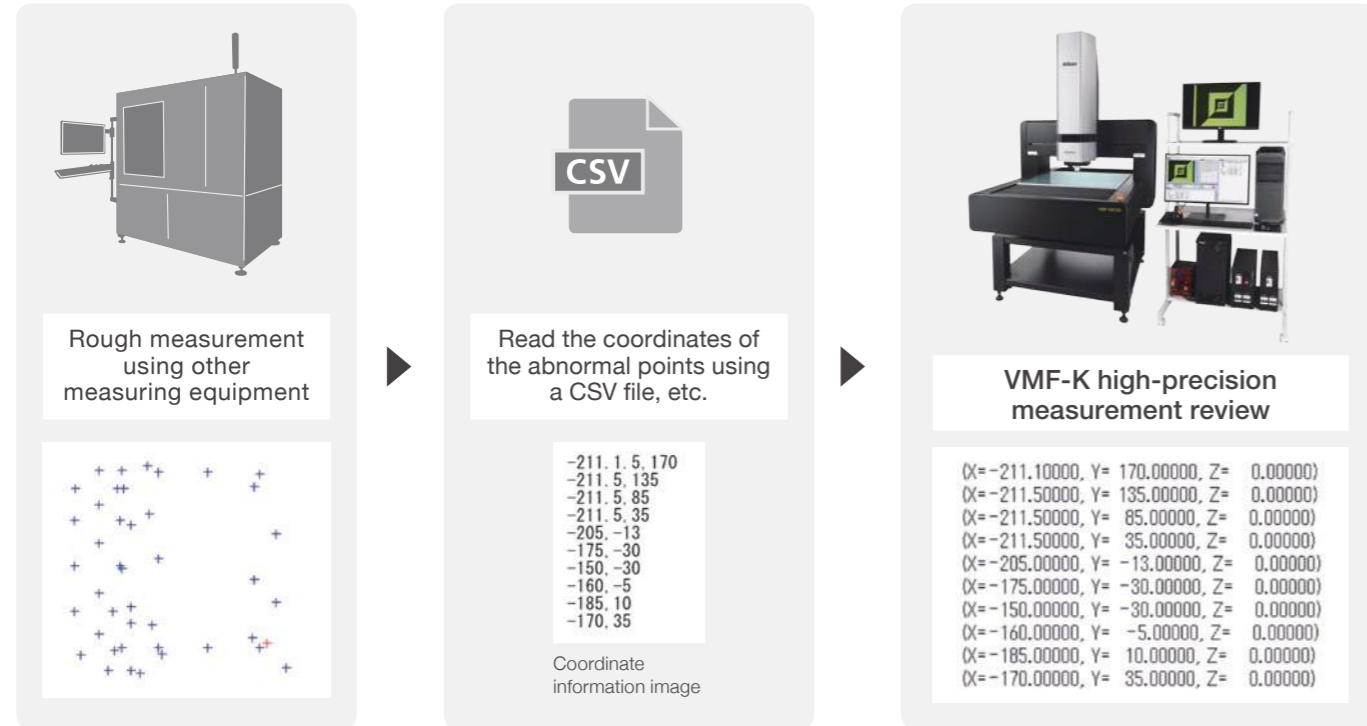

Easy measurement program creation using CAD information

Measurement conditions can be set for shapes (circles/lines/arcs) on CAD graphics, and measurement data can be generated automatically. Once you have entered the conditions on the screen and completed the setup, data will be created in the measurement program.



When CAD defined information is loaded, it is displayed in the graphics window.

Select the shape to measure from the graphic.

The program creation is completed by applying all the measurement contents to the selected shape at once.

USABILITY

Search function: automatically detects and corrects misalignment

By automatically detecting and correcting misalignments created (for example, in how samples are placed or variations in manufacture), continuous automatic measurement is possible.



Using 3D images, it is also possible to automatically detect and measure bumps and bonding wires that are misaligned from their designed positions.

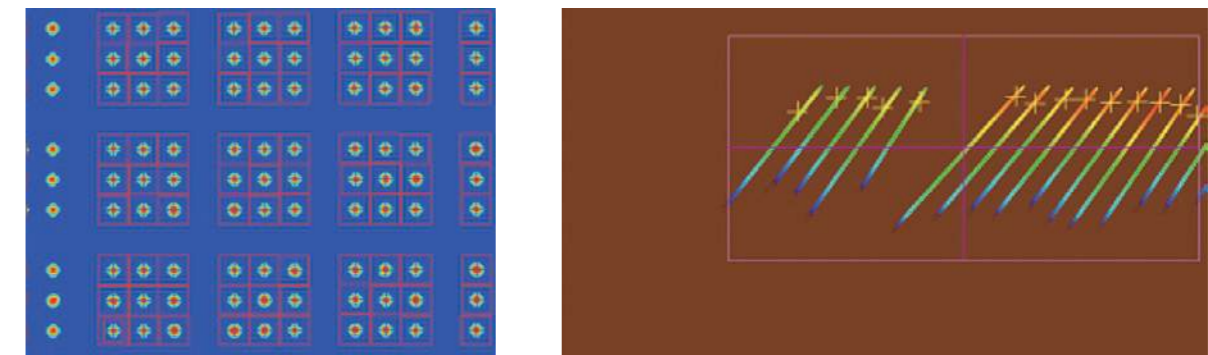

This is an example of searching for bump positions within the field of view individually. Multiple position corrections can be performed simultaneously with one detection.

When measuring bonding wires, it can automatically detect wires within a specified range and output the highest point for each.

Remaining measurement time display

This function displays the remaining measurement time in a dialog box on the screen while a measurement is in progress. When performing another task during a long measurement, there is no need to return to the device repeatedly to check the measurement progress, improving work efficiency.

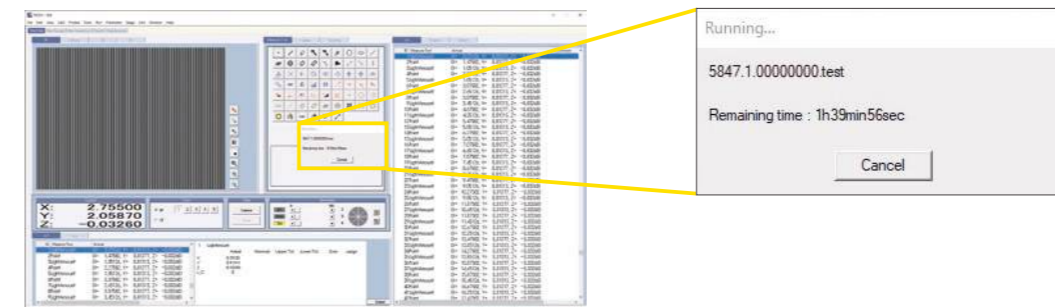

OPTIONAL SOFTWARE

Image synthesis and analysis software EDF/Stitching Express

3D images acquired by the NEXIV series can be displayed as bird's-eye views or cross-sectional shapes. In addition, multiple adjacent 3D images can be stitched together to obtain a wide-field 3D image.

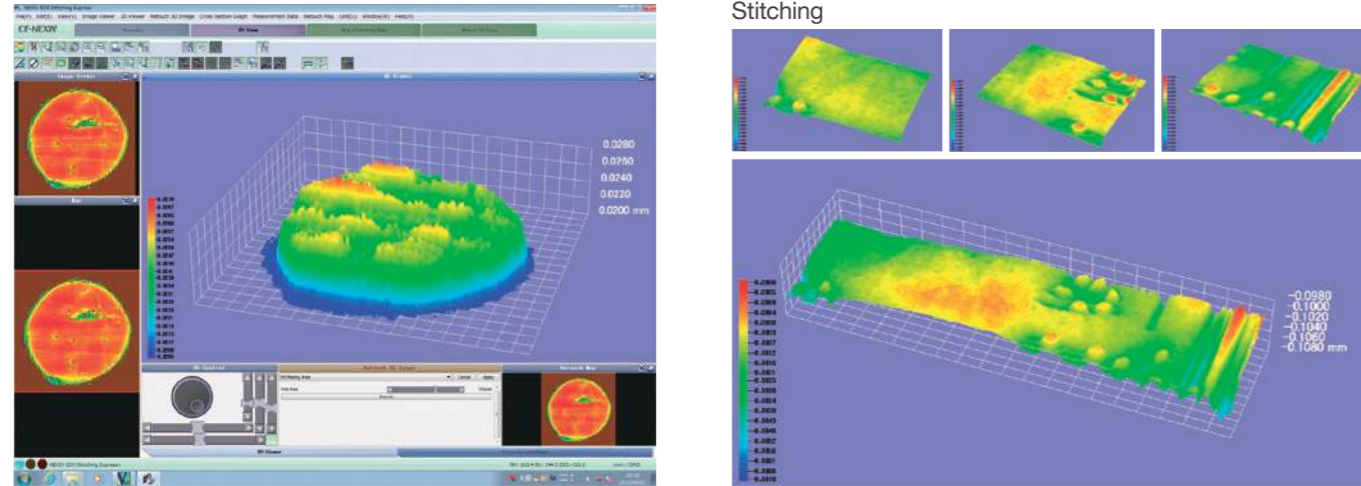

Surface shape evaluation software MountainsMap® X

This software has a wide range of functions for 3D images, such as displaying cross-sectional shapes and calculating 2D and 3D roughness based on ISO standards.

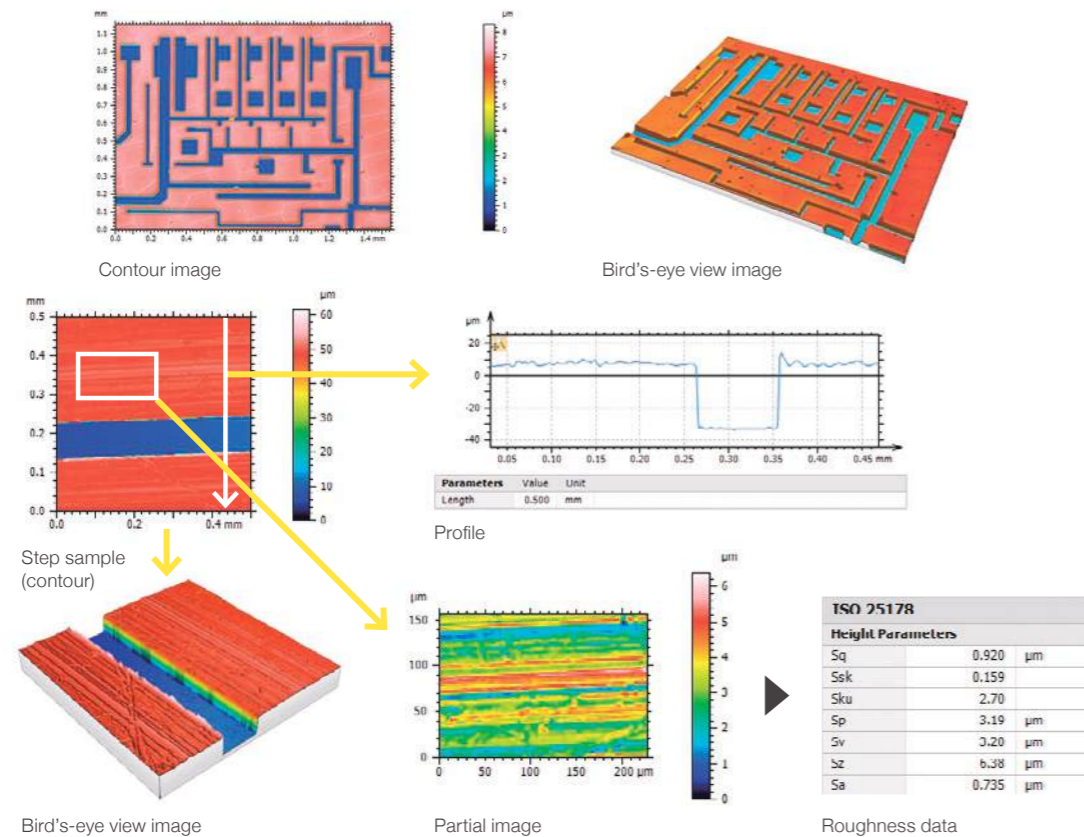

OPTIONAL HARDWARE

Wide field of view (FOV) optics for high-magnification optical heads

In addition to making it easier to find the measurement target location, the expanded search range enables stable measurement even when the sample is significantly misaligned.

Compatible optical head	15x, 30x, 45x
Field of view	4.75 mm x 3.56 mm

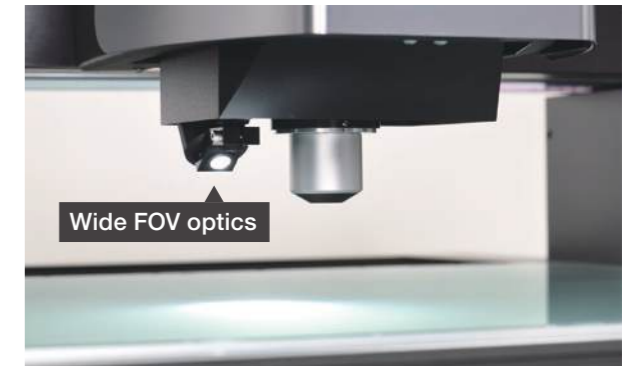

FOV comparison



Wide FOV optics

30x objective 1x (0.4 mm x 0.3 mm)

INTEGRATION

Automatic wafer/panel/tray loading solution

Nikon provides many video measuring systems to the semiconductor industry, and can flexibly respond to diverse requirements for combinations with loading systems.

Why choose Nikon?

1 Consistent support

Our dedicated technical staff will support you in determining the appropriate product specifications to meet your needs. Our technical staff will also handle after-sales service, so you can use our products with peace of mind.



2 Support for a wide variety of wafers

We provide a system that can safely load a wide variety of wafers, including wafers that are 100 μm or thinner, wafers warped by 10 mm or more, and wafers and panels with extremely limited contact points.

* Please contact us for information on panel sizes up to 600 mm.

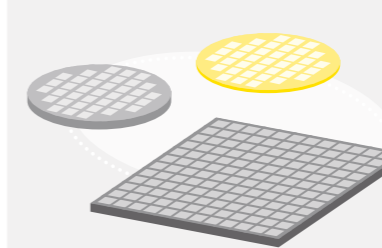

3 Excellent usability

The most important factor in operability is the ease of selecting the wafer or chip to be measured and the measurement program, so we can flexibly customize the system to meet your needs. We can also automatically transfer measurement results to a SECS/GEM compatible server/network.



SPECIFICATIONS

VMF-K3040 / VMF-K6555

Measuring head		Standard head (Type-S)			High-magnification head (Type-H)		45x High-magnification head
Optical magnification	Magnification	1.5x	3.0x	7.5x	15x	30x	45x
	Working distance	24 mm	24 mm	5 mm	20 mm	5 mm	5 mm
Confocal optics (height measurement)	Maximum scan height	1 mm					
	Field of view	7.80×5.82 mm	3.90×2.91 mm	1.56×1.17 mm	0.78×0.58 mm	0.39×0.29 mm	0.26×0.19 mm
	Height measurement repeatability (2σ)	0.6 μm	0.35 μm	0.25 μm	0.25 μm	0.2 μm	0.2 μm
	Height resolution	0.025 μm	0.01 μm				
Light source		Green LED					
Bright field optics (two-dimensional measurement)	Magnification method	Motorized 5-step zoom					
	Field of view	7.80×5.85~ 0.52×0.39 mm	3.90×2.92~ 0.26×0.19 mm	1.56×1.17~ 0.10×0.078 mm	1.26×0.95~ 0.099×0.074 mm	0.63×0.47~ 0.052×0.039 mm	0.63×0.47~ 0.052×0.039 mm
	Illumination	Diascopic, coaxial episcopic and ring				Diascopic, coaxial episcopic	
	Light source	White LED					
Autofocus		TTL Laser AF, Image AF					
Main body	Power source	AC 100V-240V ±10%, 50/60 Hz					
	Power consumption	13A-10A					
	Safety standard	SEMI S2/S8 compliance *1					

Model		VMF-K3040	VMF-K6555
Main body	XYZ strokes	300×400×150 mm	650×550×150 mm
	Accuracy guaranteed loading capacity	20 kg	30 kg
	Maximum permissible error (L: Length in mm)	Eux, MPE Euy, MPE ± (1.2 + 4 L/1000) μm Euxy, MPE ± (2.0 + 4 L/1000) μm Euz, MPE ± (1 + L/1000) μm	
	Minimum readout	0.01 μm	
Dimensions (WxDxH) and weight	Main body and table	1146×1247×1973 mm / approx. 800 kg	1198×1640×1973 mm / approx. 800 kg
	Controller	190×450×440 mm / approx. 14 kg	
	Recommended installation dimensions (WxD)*2	3150×3000 mm	3200×3300 mm
	Minimum installation dimensions (WxD)	2500×1600 mm	2500×1900 mm

*1: If installed according to SEMI guidelines, VMF-K will be compliant with SEMI S2/S8. *2: Includes our recommended maintenance space.

Specifications and equipment are subject to change without any notice or obligation on the part of the manufacturer. November 2024 ©2010-2024 NIKON CORPORATION

N.B. Export of the products* in this brochure is controlled under the Japanese Foreign Exchange and Foreign Trade Law. Appropriate export procedures shall be required in case of export from Japan.

*Products: Hardware and its technical information (including software)

 WARNING	TO ENSURE CORRECT USAGE, READ THE CORRESPONDING MANUALS CAREFULLY BEFORE USING THE EQUIPMENT.
--	---



**MICROSCOPY
METROLOGY SERVICES**

 Spisse made.

RYF AG

RYF AG
Bettlachstrasse 2
CH-2540 Grenchen
Tel +41 32 654 21 00

www.ryfag.ch

RYF SA Succursale
Route de Genève 9c
CH-1291 Commugny
Tel +41 22 776 82 28

ryfag@ryfag.ch

RYF AG (Zürich)
Im Hanselmaa 10
CH-8132 Egg / Uster/ZH
Tel +41 43 277 59 99

CHE-106.926.853 MWST
SWIFT-Code RSOSCH22
IBAN-Nr. CH80 0878 5016 0009 9850 6

