



MEASURING MICROSCOPES MM-SERIES

The lineup provides high accuracy and ease of use and meets a wide range of needs.

Measuring Microscopes

MM-Series

The MM-series are products Nikon is most proud of, with a variety of enhanced features such as higher measurement accuracy and coordination with data processing systems.



MM-Type
MM-400N/LV

- In addition to the easy-to-use design, an motorized vertical movement mechanism is available.
- Newly developed transmissive lighting enables to switch white and green LED light.
- Stages can be selected from 3 types for MM-400N and 6 types for MM-800N (max 300x200 mm).
- Digital image measurement is possible with the E-MAX (V3 set) measurement support system.
- Data processing unit DP-E1A which combines high functionality and ease of use is available.
- The coarse/fine movement switching lever and RESET/SEND button are near the X/Y axis handle of the stage.
- Aperture diaphragm function for transmitted illuminator is available for both MM-400N and MM-800N, supporting the measurement of cylindrical parts.
- Power consumption has been reduced by 10%*1 compared to the former MM-400/MM-800 series models. The manufacturer provides environmentally friendly products and complies with the RoHS Directive and other laws and regulations*2.

*1. Calculated based on Nikon evaluation values *2. Based on Nikon standards, in consideration of domestic and foreign laws and regulations



X-axis handle (around switch)



Y-axis handle (around switch)



U-Type
MM-800N/U

Function Icons

- FA Focusing Aid**
The Focusing Aid (FA) ensures accurate Z-axis focusing.
- UFA Universal Epi-illuminator Focusing Aid**
A universal epi-illuminator with Focusing Aid (FA) mechanism.
- Variable Magnification**
Two objective lenses can be attached, making magnification changeover easy.
- Z-axis Motorized Motion**
A dedicated controller provides easy and accurate up/down movements.
- 2 Dual Side Coarse/Fine Focus Knob**
Coarse/fine focus knobs are on both sides.
- L Built-in Z-axis Linear Scale**
Z-axis reading is possible for non-contact height measurement.
- T Trinocular Optical Head**
Ideal for configuration with photomicrography equipment.
- M Monocular Optical Head**
For applications where cost performance is priority.
- U-EPI Universal Epi-illuminator**
Supports a wide range of applications.
- LED LED Illuminator**
A high-intensity white LED illuminator for brightfield use.

MM TYPE

Z Motorized	Variable Magnification	Z-axis Linear Scale	Basic
MM-800N/LMT MM-800N/LMFA MM-400N/LMT MM-400N/LMFA	MM-800N/LV MM-800N/LVFA MM-400N/LV MM-400N/LVFA	MM-800N/LT MM-800N/SLT MM-400N/LT MM-400N/SLT MM-800N/LFA MM-400N/LFA	MM-800N/T MM-800N/ST MM-400N/T MM-400N/ST MM-400N/M MM-400N/SM
P6	P6	P7	P7

UNIVERSAL TYPE

Z Motorized	Z-axis Linear Scale	Basic
MM-800N/LMU MM-400N/LMU	MM-800N/LU MM-800N/SLU MM-400N/LU MM-400N/SLU	MM-800N/U MM-800N/SU MM-400N/U MM-400N/SU
P8	P8	P9

MM TYPE

Highly accurate measurement is achieved with proven optical technology and control functions.

Improved lighting performance for wide range of needs

LED Illuminator

The newly developed diascope LED illuminator has now both white and green light sources, and the operator can easily switch the light without inserting or removing filters. The high-intensity white LED lighting has a constant color temperature and the light modulator responds quickly, so efficient high-precision measurement is possible. Furthermore, it has low power consumption and long life.



LED transmissive illuminator LED reflective illuminator

8-segment LED Ring Light CYN-E1 (option for MM-type)

- Highlights the edges of samples that are difficult to see under normal lighting, such as plastic molded products.
- Selectable 8-segment ON/OFF LED with a large amount of light and a 30° angle of incidence.
- Compatible with 1x, 3x, 5x, and 10x measuring microscope objective lenses

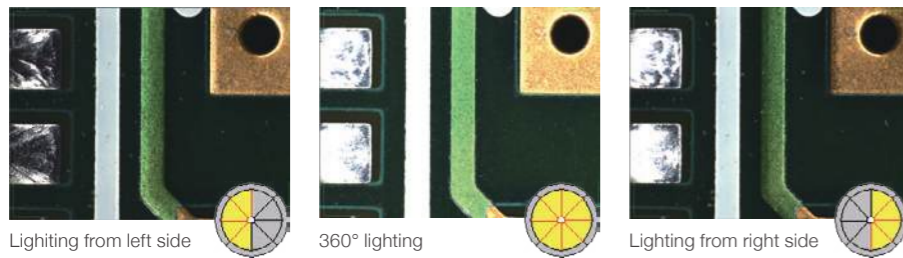

Lighting from left side 360° lighting Lighting from right side



8-segment LED Ring Light CYN-E1

Improved accuracy/repeatability of height measurements

Focusing Aid (FA)

A newly developed split-prism-type FA with a clear pattern makes it possible to accurately focus in the Z-axis and reduces height measurement errors caused by the depth of field of the objective lens. There are two types of patterns, light and dark, and it is possible to switch between them according to the surface properties of the test object.

The mechanism of the split-prism-type FA

Objective lens Focused in front Focused Focused beyond

Focused in front Focused Focused beyond

Objective lenses for MM TYPE

These compact objectives feature long working distance and excellent resolution, which helps to reduce measurement errors.



Magnification	1x	3x	5x	10x	20x	50x	100x
WD (mm)	79	75	64	48	20	15	4
NA	0.03	0.09	0.13	0.2	0.4	0.55	0.75
Physical depth of focus (μm)	305.5	33.9	16.2	6.8	1.7	0.9	0.4
F.O.V for eyepieces (CFWN 10x F.N.20)	20	6.66	4	2	1	0.4	0.2

UNIVERSAL TYPE

Enhanced the accuracy of height measurements and a variety of illuminators make possible both an expanded observation area and high-precision measurement

Lineup of a variety of illuminators

- **Universal Reflective Illuminator LV-UEPI2**
Optimal illumination conditions can be linked to the field of view aperture, aperture diaphragm, and shutter.
- **Universal Reflective Illuminator LV-UEPI**
Automatically opens the field of view aperture and aperture diaphragm when switching between brightfield and darkfield.
- **FA Reflective Illuminator LV-UEPI FA**
Has the FA for more precise height measurement.



FA Reflective Illuminator LV-UEPI FA

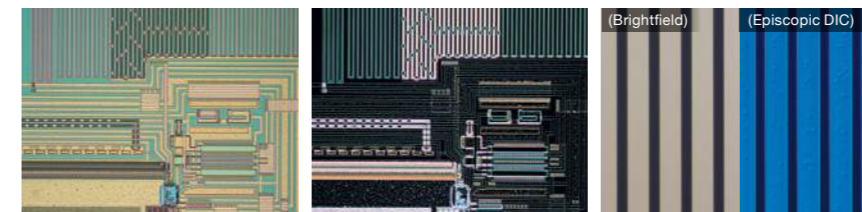

Brightfield Semiconductors (IC wafers) **Darkfield** Semiconductors (IC wafers) **Episcopic DIC** Substrate

	Brightfield	Darkfield	DIC	Polarizing
Episcopic (Halogen)	○	○	○	△*
Episcopic (LED)	○	○	○	△*
Diascopic (LED)	○	—	—	—

* only simple polarizing observation

Enhanced accuracy/repeatability of height measurements

Focusing Aid (FA)

There is a newly developed split-prism type FA. It enables more accurate focusing and reduces measurement errors caused by the depth of field of the objective lens. (Must be used with the LV-UEPI FA illuminator.)

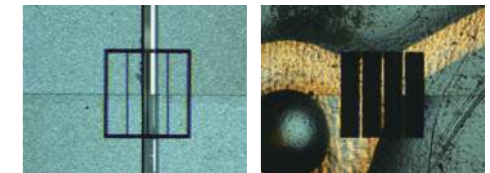

Dark line pattern Light line pattern

Objective lenses for UNIVERSAL TYPE

This new optical system combines excellent chromatic aberration correction and long working distances. The edge detection for the location being measured and operability have been improved, and a wider variety of samples can be handled.

Observation Methods	Type	Magnifications	NA	WD (mm)	Physical depth of focus(μm)	F.O.V for eyepieces (CFI 10x F.N.22)
Brightfield	TU Plan Fluor EPI	5x	0.15	23.5	12.22	4.4
		10x	0.30	17.5	3.06	2.2
		20x	0.40	19.0	1.72	1.1
Brightfield/ Darkfield	TU Plan EPI ELWD	50x	0.50	11.0	0.76	0.44
		100x	0.80	4.5	0.43	0.22
		TU Plan Fluor BD	5x	0.15	18.0	12.22
10x	0.30		15.0	3.06	2.2	
20x	0.40		19.0	1.72	1.1	
Brightfield/ Darkfield	TU Plan BD ELWD	50x	0.60	11.0	0.76	0.44
		100x	0.80	4.5	0.43	0.22

MM TYPE

Z Motorized

Vertical movement is motorized so it is easy on the operator, and precise movements are possible. When combined with the FA trinocular observation unit height measurement error can be minimized.

MM-800N/LMT
MM-400N/LMT

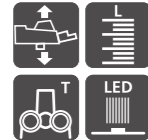

MM-800N/LMFA
MM-400N/LMFA

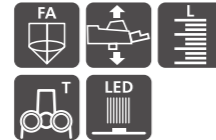

Variable magnification

Two objective lenses, low magnification and high magnification, can be mounted and it is easy to switch between them. A single microscope can efficiently perform wide-field measurement at low magnification and high-precision height measurement at high magnification.

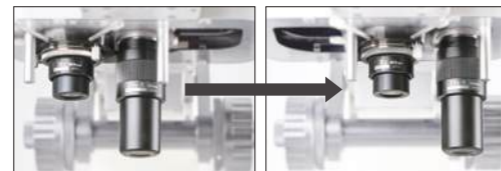

MM-800N/LV
MM-400N/LV



MM-800N/LVFA
MM-400N/LVFA

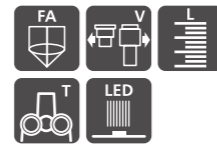

Main Specifications

Model	MM-800N/LMT, MM-800N/LMFA	MM-800N/LV, MM-800N/LVFA	MM-400N/LMT, MM-400N/LMFA	MM-400N/LV, MM-400N/LVFA
Z-axis movement	Motorized (max. speed: 10 mm/sec)	Manual (dual side coarse/fine focus knob)	Motorized (max. speed: 10 mm/sec)	Manual (dual side coarse/fine focus knob)
Optical head	Trinocular optical head, Trinocular optical FA head	Variable magnification optical head, Variable magnification optical FA head	Trinocular optical head, Trinocular optical FA head	Variable magnification optical head, Variable magnification optical FA head
Eyeiece inclination angle	25°			
Eyeiece	CFWN10X (Field No. 20)			
Objective lenses (WD)	Measuring microscope objectives 1X (79 mm), 3X (75 mm), 5X (64 mm), 10X (48 mm), 20X (20 mm), 50X (15 mm), 100X (4 mm)	Low magnification: 1X (79 mm), 3X (75 mm), 5X (64 mm), 10X (48 mm), 20X (20 mm), 50X (15 mm), 100X (4 mm) High magnification: 5X (64 mm), 10X (48 mm), 20X (20 mm), 50X (15 mm), 100X (4 mm)	Measuring microscope objectives 1X (79 mm), 3X (75 mm), 5X (64 mm), 10X (48 mm), 20X (20 mm), 50X (15 mm), 100X (4 mm)	Low magnification: 1X (79 mm), 3X (75 mm), 5X (64 mm), 10X (48 mm), 20X (20 mm), 50X (15 mm), 100X (4 mm) High magnification: 5X (64 mm), 10X (48 mm), 20X (20 mm), 50X (15 mm), 100X (4 mm)
Stage**	MHS 12x8C, MHS 10x6B, MHS 8x6B, MHS 6x4B, MHS 4x4B, MHS 2x2B	MHS 6x4B, MHS 4x4B, MHS 2x2B		
Light Source	Diascopic: White LED (standard), Green LED (standard) / Episcopic: White LED			
Maximum sample height	200 mm		150 mm	
Dimensions (WxDxH), Weight (approx.) ²	380(W)×703(D)×725(H)mm, Approx. 72 kg		300(W)×567(D)×638(H)mm, Approx. 50 kg	

*1: When attaching a MHS 6x4B, MHS 4x4B, or MHS 2x2B stage to MM-800N, a stage adapter is required.
*2: Excludes stage and eyepiece

Z-axis linear encoder

Dual-axis handle type with built-in Z-axis scale. An FA trinocular optical head or non-FA trinocular optical head can be selected according to the application.

MM-800N/LT
MM-800N/SLT
MM-400N/LT
MM-400N/SLT



MM-800N/LFA
MM-400N/LFA

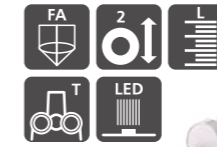

Basic

These are basic types for the MM-800N and 400N measuring microscopes with excellent cost performance. The optical head and stage can be selected according to the measurement application. (for XY measurement only)

MM-800N/T
MM-800N/ST
MM-400N/T
MM-400N/ST



MM-400N/M
MM-400N/SM









Main Specifications

Model	MM-800N/L, MM-800N/LFA, MM-800N/SLT	MM-400N/L, MM-400N/LFA, MM-400N/SLT	MM-800N/T, MM-800N/ST	MM-400N/T, MM-400N/ST	MM-400N/M
Z-axis movement	Manual (dual side coarse/fine focus knob)				
Optical head	Trinocular optical head, Trinocular optical FA head			Trinocular optical head	Monocular optical head
Eyeiece inclination angle	25°				30°
Eyeiece	CFWN10X (Field No. 20)				
Objective lenses (WD)	Measuring microscope objectives 1X (79 mm), 3X (75 mm), 5X (64 mm), 10X (48 mm), 20X (20 mm), 50X (15 mm), 100X (4 mm)				
Stage**	MHS 12x8C, MHS 10x6B, MHS 8x6B, MHS 6x4B, MHS 4x4B, MHS 2x2B	MHS 6x4B, MHS 4x4B, MHS 2x2B	MHS 12x8C, MHS 10x6B, MHS 8x6B, MHS 6x4B, MHS 4x4B, MHS 2x2B	MHS 6x4B, MHS 4x4B, MHS 2x2B	
Light Source	Diascopic: White LED (standard), Green LED (standard) / Episcopic: White LED				
Maximum sample height	200 mm		150 mm		
Dimensions (WxDxH), Weight (approx.) ²	380(W)×703(D)×725(H)mm, Approx. 72 kg	300(W)×567(D)×638(H)mm, Approx. 50 kg	380(W)×703(D)×725(H)mm, Approx. 72 kg	300(W)×567(D)×638(H)mm, Approx. 50 kg	

*1: When attaching a MHS 6x4B, MHS 4x4B, or MHS 2x2B stage to MM-800N, a stage adapter is required.
*2: Excludes stage and eyepiece

Function Icons

-  **Focusing Aid**
The Focusing Aid (FA) ensures accurate Z-axis focusing.
-  **Universal Epi-illuminator Focusing Aid**
A universal epi-illuminator with Focusing Aid (FA) mechanism.
-  **Variable Magnification**
Two objective lenses can be attached, making magnification changeover easy.
-  **Z-axis Motorized Motion**
A dedicated controller provides easy and accurate up/down movements.
-  **Dual Side Coarse/Fine Focus Knob**
Coarse/fine focus knobs are on both sides.
-  **Built-in Z-axis Linear Scale**
Z-axis reading is possible for non-contact height measurement.
-  **Trinocular Optical Head**
Ideal for configuration with photomicrography equipment.
-  **Monocular Optical Head**
For applications where cost performance is priority.
-  **Universal Epi-illuminator**
Supports a wide range of applications.
-  **LED Illuminator**
A high-intensity white LED illuminator for brightfield use.

UNIVERSAL TYPE

Z Motorized

Universal-type with motorized vertical movement with universal reflective illuminator capable of brightfield, darkfield, simple polarization, and differential interference observation.

MM-800N/LMU
MM-400N/LMU

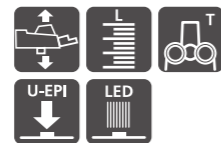

Z-axis linear encoder

Dual-axis handle type with built-in Z-axis scale. Combining with the LV-UEPI FA reflective illuminator, high-precision height measurements can be made.

MM-800N/LU
MM-800N/SLU

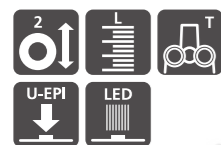

MM-400N/LU
MM-400N/SLU



■ Main Specifications

Model	MM-800N/LMU	MM-400N/LMU	MM-800N/LU, MM-800N/SLU	MM-400N/LU, MM-400N/SLU
Z-axis movement	Motorized (max. speed: 10 mm/sec)		Manual (dual side coarse/fine focus knob)	
Eyepiece Tube	C-TB binocular tube, LV-TI3 trinocular eyepiece tube, LV-TT2 tilting trinocular eyepiece tube (with built-in reticle)			
Eyepiece	CFI10X (Field No. 22), CFI10XCM (Field No. 22)			
Objective lenses	TU Plan FLUOR EPI series, TU Plan FLUOR BD series, CFI L Plan EPI CR series			
Stage ^{*1}	MHS 12x8C, MHS 10x6B, MHS 8x6B, MHS 6x4B, MHS 4x4B, MHS 2x2B	MHS 6x4B, MHS 4x4B, MHS 2x2B	MHS 12x8C, MHS 10x6B, MHS 8x6B, MHS 6x4B, MHS 4x4B, MHS 2x2B	MHS 6x4B, MHS 4x4B, MHS 2x2B
Light Source	Diascopic: White LED (standard), Green LED (standard)			
	Episcopic: Universal epi-illuminator with Focusing Aid LV-U EPI FA, Universal epi-illuminator LV-U EPI2 ^{*2} , Universal epi-illuminator U-EPI ^{*2} , MM-LL LED Lamphouse (option for LV-U EPI and LV-U EPI2) ^{*2}			
Maximum sample height	200 mm	150 mm	200 mm	150 mm
Dimensions (WxDxH), Weight (approx.) ^{*3}	380(W)×703(D)×725(H)mm, Approx. 72 kg	300(W)×567(D)×638(H)mm, Approx. 50 kg	380(W)×703(D)×725(H)mm, Approx. 72 kg	300(W)×567(D)×638(H)mm, Approx. 50 kg

*1: When attaching a MHS 6x4B, MHS 4x4B, or MHS 2x2B stage to MM-800N, a stage adapter is required.

*2: Used with TI-PS100W power supply + MM-LH60PC *3: Excludes stage and eyepiece

Basic

Basic universal-type with universal reflective illuminator capable of brightfield, darkfield, simple polarization, and differential interference observation. (for XY measurement only)

MM-800N/U
MM-800N/SU



MM-400N/U
MM-400N/SU



■ Main Specifications

Model	MM-800N/U, MM-800N/SU	MM-400N/U, MM-400N/SU
Z-axis movement	Manual (dual side coarse/fine focus knob)	
Eyepiece Tube	C-TB binocular tube, LV-TI3 trinocular eyepiece tube, LV-TT2 tilting trinocular eyepiece tube (with built-in reticle)	
Eyepiece	CFI10X (Field No. 22), CFI10XCM (Field No. 22)	
Objective lenses	TU Plan FLUOR EPI series, TU Plan FLUOR BD series, CFI L Plan EPI CR series	
Stage ^{*1}	MHS 12x8C, MHS 10x6B, MHS 8x6B, MHS 6x4B, MHS 4x4B, MHS 2x2B	MHS 6x4B, MHS 4x4B, MHS 2x2B
Light Source	Diascopic: White LED (standard), Green LED (standard)	
	Episcopic: Universal epi-illuminator with Focusing Aid LV-U EPI FA, Universal epi-illuminator LV-U EPI2 ^{*2} , Universal epi-illuminator U-EPI ^{*2} , MM-LL LED Lamphouse (option for LV-U EPI and LV-U EPI2) ^{*2}	
Maximum sample height	200 mm	150 mm
Dimensions (WxDxH), Weight (approx.) ^{*3}	380(W)×703(D)×725(H)mm, Approx. 72 kg	300(W)×567(D)×638(H)mm, Approx. 50 kg

*1: When attaching a MHS 6x4B, MHS 4x4B, or MHS 2x2B stage to MM-800N, a stage adapter is required.

*2: Used with TI-PS100W power supply + MM-LH60PC *3: Excludes stage and eyepiece

■ Function Icons

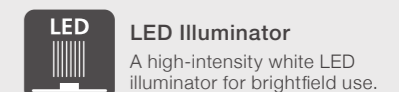
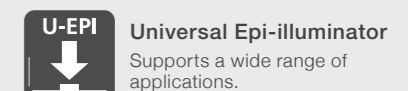
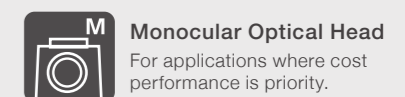
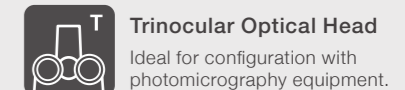
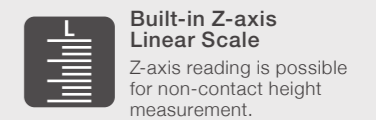
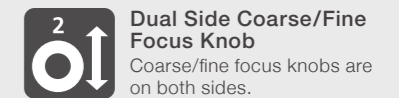
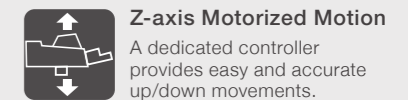
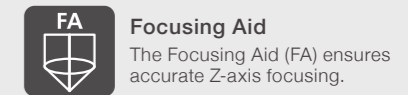

ACCESSORIES

Stages

Stages for MM-800N series

PS 12x8C Stage

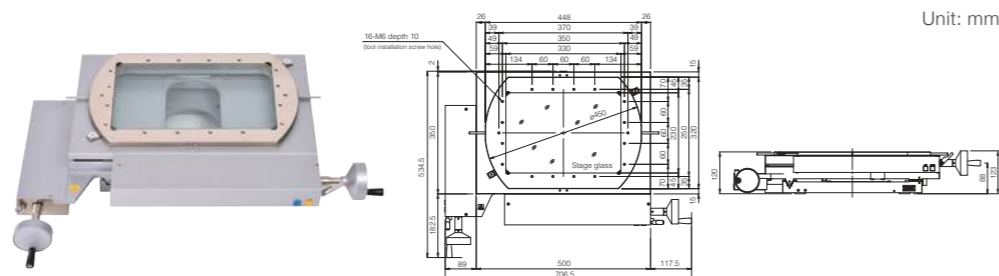

Unit: mm

PS 10x6B Stage

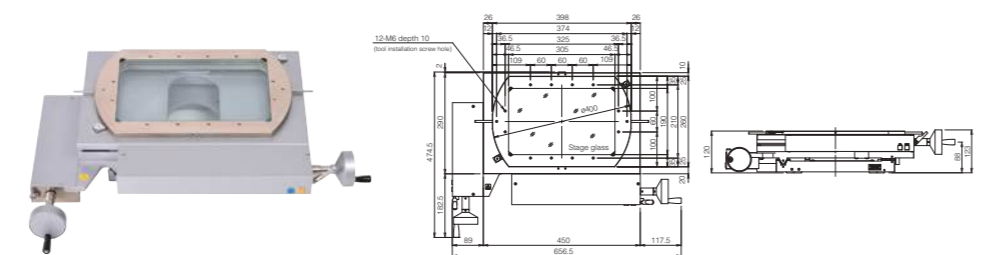

PS 8x6B Stage

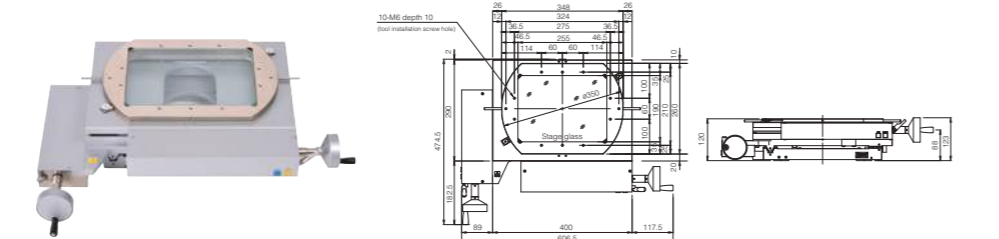

Stages for MM-400N series

PS 6x4B Stage

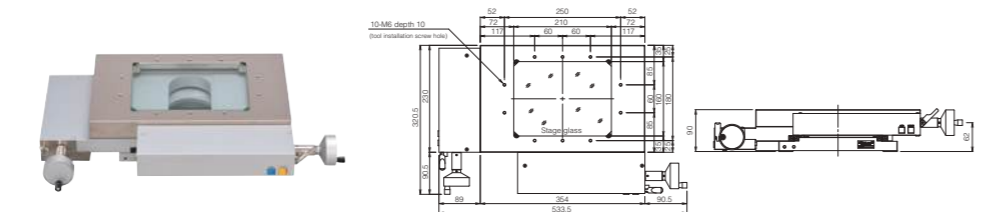

PS 4x4B Stage

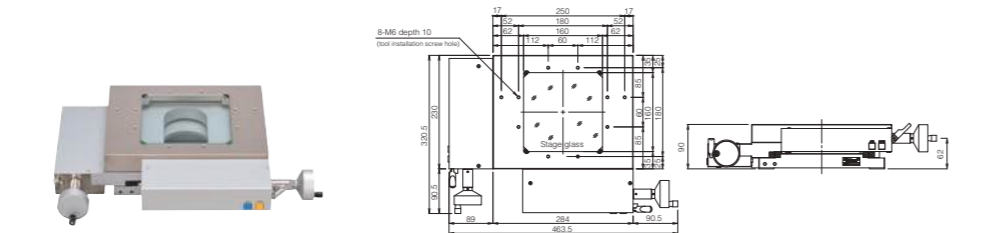

PS 2x2B Stage

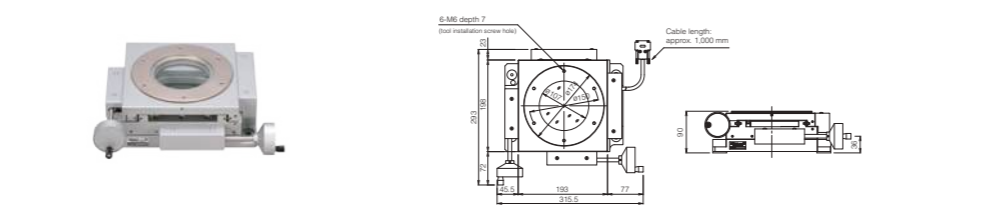

Stage specifications

Type	Surface area (mm)	Stage glass dimensions (mm)	Stroke (mm)	Reading method	Min. reading (μm)	Rotation range	Tool installation screw hole	Loading capacity (kg)	Weight (approx.)(kg)
PS 12x8C	448×320	330×230	300×200	Linear encoder	0.01	±3° (Swivel plate)	16-M6 depth 10	20	67
PS 10x6B	398×260	305×190	250×150				12-M6 depth 10		51.5
PS 8x6B	348×260	255×190	200×150				10-M6 depth 10		48.5
PS 6x4B	354×230	210×160	150×100			10-M6 depth 10	27.5		
PS 4x4B	284×230	160×160	100×100			8-M6 depth 10	23.5		
PS 2x2B	Ø174	Ø107	50×50			360° (Rotating table)	6-M6 depth 7	5	15.5

MM Series High-Precision Type

Nikon offers High-Precision Type measuring microscopes for customers who need higher precision. High-Precision Type is calibrated by a certified engineer for customer site.

Combination precision (example)

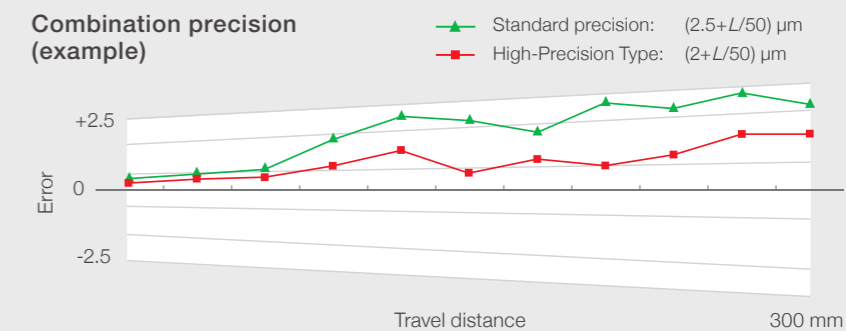

Accuracy (with MM main body)

2.0 + L/50 μm (High-Precision Type)*
2.5 + L/50 μm (Standard Type; calibration data included)*

Stage

MHS 12x8C, MHS 10x6B, MHS 8x6B, MHS 6x4B, MHS 4x4B, MHS 2x2B

To ensure accuracy, both types require a temperature controlled room. *Please contact Nikon for details regarding High-Precision Type.

Rotating Tables

Rotating Table Type 4

For PS 12x8C*, PS 10x6B, PS 8x6B

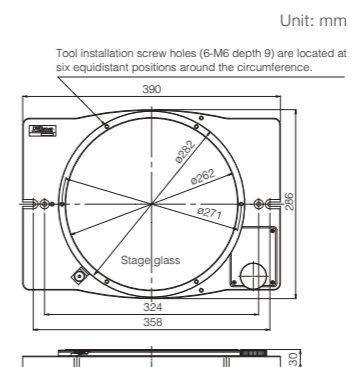

*When using rotating table type 4, stage stroke is limited for X and Y axis.

Rotating Table Type 3

For PS 6x4B, PS 4x4B

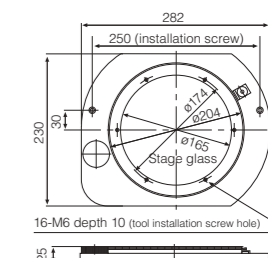

Rotating table specifications

Table	Table size(mm)	Glass insert size (mm)	Rotation range	Tool installation screw hole	Weight (kg)
Type 4	ø282	ø262	360° (uncalibrated)	6-M6 depth 9	Approx. 8
Type 3	ø204	ø165	360° (uncalibrated)	6-M6 depth 10	Approx. 5

Tilting Center Fixture A

Used to hold machined samples for PS 2x2B, Rotating Table Type 3.



Max. sample diameter and length when held level (mm)	Center height (mm)	Tilting angle	Weight (kg)
ø68×120	45	10°(in 1° increment)	Approx. 2.2

Large Stage Adjustment Knob

Enables fine adjustment of swivel plate rotation for PS 12x8C, PS 10x6B and PS 8x6B.



ACCESSORIES

Objectives 1x, 3x, 5x, 10x, 20x, 50x, 100x

These compact objectives feature long working distance and excellent resolution. Almost all have the same parfocal distances and come with lens adapters for quick and easy replacement.

- 3x objective is included with the measuring microscope.
- For installation on the optical head, an objective lens adapter is required. (excluding variable magnification optical head)



These objective lenses use eco-friendly glass that does not contain lead, arsenic, or toxic substances, making them meet the environmental needs of the times.

Magnification	1x	3x	5x	10x	20x	50x	100x
WD (mm)	79	75	64	48	20	15	4
NA	0.03	0.09	0.13	0.2	0.4	0.55	0.75
Physical depth of focus (μm)	305.5	33.9	16.2	6.8	1.7	0.9	0.4
F.O.V for eyepieces (CFWN 10x F.N.20)	20	6.66	4	2	1	0.4	0.2

Illuminators

8-Segment LED Ring Light

Enables illumination from eight directions.

- Can be used with E-MAX RS-232C cable comes standard
- E-BUS cable is required to control with E-MAX



*Ring illuminator adapter is required for installation.

• Substrate



Reflective lighting



8-Segment LED ring light

• Rubber goods



Reflective lighting



8-Segment LED ring light

• Substrate



Transmissive lighting

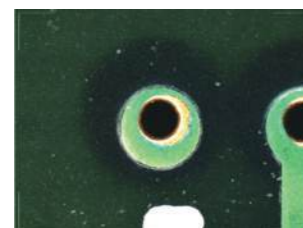

8-Segment LED ring light (360°)

Fiber-optics Illuminator Set

Offers easily adjustable brightness. The ring fiber illuminator minimizes shadows caused by any unevenness on the sample surface. The bifurcated fiber enables illumination from two directions.

- Cannot be used with metallurgical microscope objectives
- Cannot be mounted when using 20x, 50x and 100x measuring microscope objectives



LED Ring Illuminator

Ideal for use in a production environment as LEDs have long product life. Uses white LEDs with a variable intensity control and constant color temperature.

- Cannot be used with metallurgical microscope objectives
- Cannot be mounted when 20x, 50x and 100x measuring microscope objectives are used

Protractor Eyepieces (for MM Type only)

Note: Monocular adapter is required when using these eyepieces with trinocular tubes

Digital Protractor Eyepiece*

Rotate crosshairs in the viewfield to measure angles.

Display unit: 1 minute, 10 minutes

*Not available for S and SL models



1-Minute Reading Eyepiece

Viewfield includes crosshairs and 60° lines. Angle indexes are read by appropriate microscopes.

Measuring range: 360°



10-Minute Reading Eyepiece

Viewfield includes crosshairs and angle indexes. When the knurled ring at the lower section of the eyepiece tube is turned, the crosshairs and the vernier both rotate 180°.



Direct C-mount Adapter

Used to install C-mount camera on the measuring microscope.

- LV-TV tube is required

ACCESSORIES

The use of the CFI60-2 series of high-performance objective lenses is possible, further improving optical performance

The TU Plan Fluor series of standard objective lenses with both excellent chromatic aberration correction and long working distances

This is a universal-type standard objective lens that make possible all observation methods with a single objective lens: brightfield, darkfield, simple polarization, differential interference, and epifluorescence using not only the visible region but also the UV region.

This new optical system combines excellent chromatic aberration correction and long working distances. The edge detection for the location being measured and operability have been improved, and a wider variety of samples can be handled.



TU Plan Fluor series

• Brightfield

Type	Magnifications	NA	WD (mm)	Physical depth of focus(μm)	F.O.V for eyepieces (CFI 10x F.N.22)
TU Plan Fluor EPI	5x	0.15	23.5	12.22	4.4
	10x	0.30	17.5	3.06	2.2
	20x	0.40	19.0	1.72	1.1
TU Plan EPI ELWD	50x	0.50	11.0	0.76	0.44
	100x	0.80	4.5	0.43	0.22

• Brightfield/Darkfield

Type	Magnifications	NA	WD (mm)	Physical depth of focus(μm)	F.O.V for eyepieces (CFI 10x F.N.22)
TU Plan Fluor BD	5x	0.15	18.0	12.22	4.4
	10x	0.30	15.0	3.06	2.2
	20x	0.40	19.0	1.72	1.1
TU Plan BD ELWD	50x	0.60	11.0	0.76	0.44
	100x	0.80	4.5	0.43	0.22

Objective lenses with cover glass thickness correction rings
The CFI L Plan EPI CR Series

These are objective lenses with correction rings. High-contrast observation of cells and patterns is possible without being affected by the cover glass.

• With correction mechanism

Type	Magnification	NA	W.D.(mm)	Glass thickness correction range (mm)
CFI L Plan EPI CR	20x	0.45	10.9-10.0	0-1.2
CFI L Plan EPI CR	50x	0.7	3.9-3.0	0-1.2
CFI L Plan EPI CRA	100x	0.85	1.2-0.85	0-0.7
CFI L Plan EPI CRB	100x	0.85	1.3-0.95	0.6-1.3

Environmental Considerations

The TU Plan Fluor and CFI L Plan EPI CR series use eco-friendly glass that does not contain lead, arsenic, or toxic substances, making them meet the environmental needs of the times.



The CFI L Plan EPI CR series with correction rings



No correction for cover glass thickness (with 50x objective lens)

Corrected for cover glass thickness of 0.7 mm (with 50x objective lens)

Tilting trinocular eyepiece tube

Tilting trinocular eyepiece tube

The LV-TT2 tilting trinocular eyepiece tube with built-in reticle offers comfort to all users, regardless of their viewing positions. The optical path changeover of 100:0/20:80 allows simultaneous use of a monitor.



Light source

In addition to a halogen lamp, a compact LED EPI lamphouse for brightfield, darkfield, and DIC observations is available.



Manual nosepieces

A variety of manual control nosepieces are available to suit all needs.

	Brightfield	Darkfield	DIC
C-N6	○	—	—
L-NBD5	○	○	—
L-NU5	○	○	○

○ : Supported — : Not supported

Templates

The following dedicated templates are available to facilitate profile comparison and measurements. Templates are designed for 3x objectives.

- Standard angle templates (standard)
- Concentric (diameter 0.2-4.6)*

*Cannot be attached to monocular type

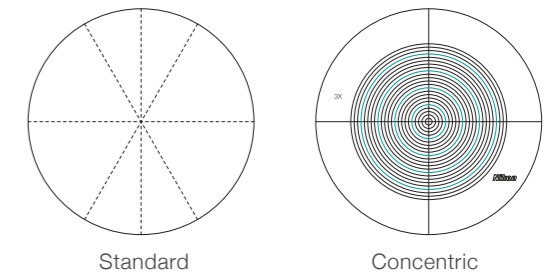

Standard

Concentric

DP-E1A

Data Processor with improved accuracy and ease of use

Effectively used in combination with a measuring microscope/profile projector, the DP-E1A quickly calculates geometrical features with simple and interactive operations. Measurement results are automatically memorized as teaching steps and can be easily used as a measurement routine.

Simple & interactive operation

Feature Oriented Operation allows the user to conduct measurements by following the graphics, providing a seamless measuring environment. Measurement results are automatically memorized as teaching steps and can be easily used as a measurement routine.

GD&T compliance

Geometric Dimensioning & Tolerancing defined by the ANSI Y 14.5M Specification is supported. In addition to Location Tolerancing such as True Position, MMC and LMC, determination of Form, Orientation and Runout can be conducted interactively.

Multi-language support

English, German, Japanese and various other Asian and European languages are supported.



ACCESSORIES

E-Max Series

FOV Measurement with advanced digital image processing technology

Combined with the V3 digital camera, E-MAX series software provides various advanced measurements and processing functions, ranging from 2D data processing and image measurement, to data storage. Automated edge detection with sub-pixel processing enables more precise and repeatable measurement.



E-MAX V3 set

High-resolution digital images

High-resolution image measurement is possible with the combination of a digital camera and a measuring microscope. Images displayed in the video window can be saved in BMP or JPEG format.

Automated edge detection and automatic replay functions

Simply moving the stage to the navigated measurement area enables automatic in-screen measurement during replay. In addition, edge detection is done by automatically correcting the position of the stored image, greatly reducing measurement time and cost.

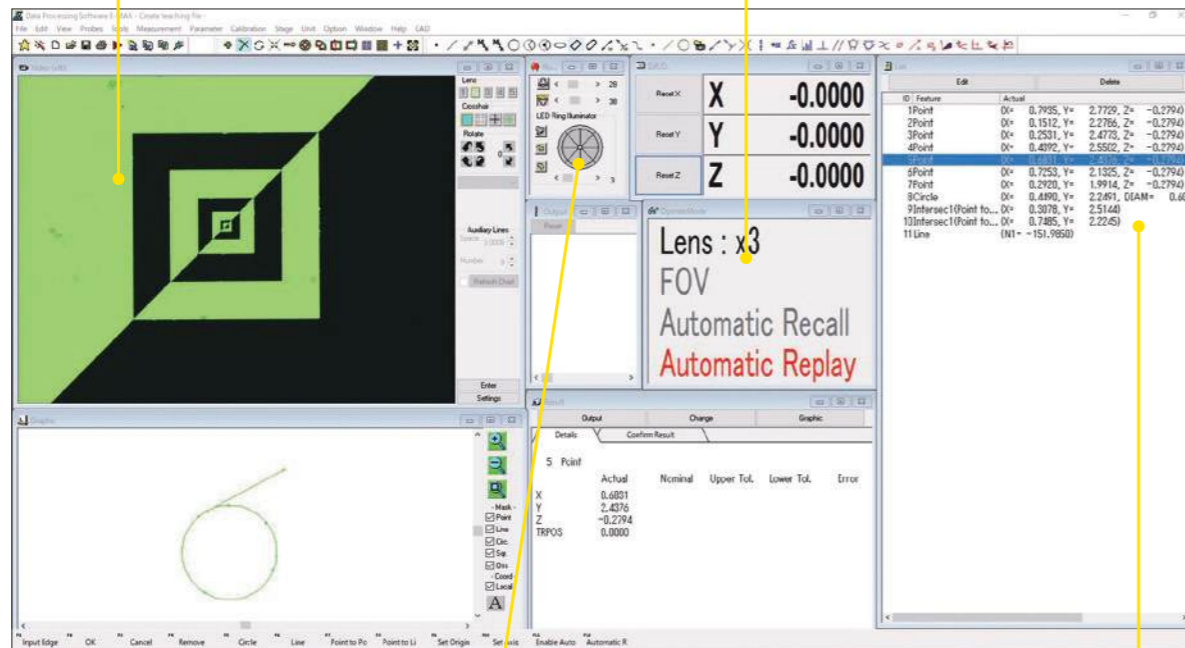

E-MAX screen

Automatic Light Adjustment

Saves the lighting conditions at the time of teaching for each point input, and reproduces them accurately on replay.

One-click output to Excel

Measurement results can be displayed in Excel in real time. Even during manual measurements, measurement result files can be saved and Excel can be launched from E-MAX for speedy work.

Application Software for Measurement Support/Data Processing System

Custom Fit QC: Report and chart generating

Suitable for lot control of inspection data such as maximum value, minimum value, range, standard deviation, and process capability index.

- Customization of inspection result sheets are possible, in addition to the 10 standard sheets
- BMP and JPEG files can be pasted onto the inspection result sheets
- Graphs can be automatically generated
- Displays are adjustable between degree/minute/second
- Easy to generate histograms, X-R control charts, and scatter diagrams

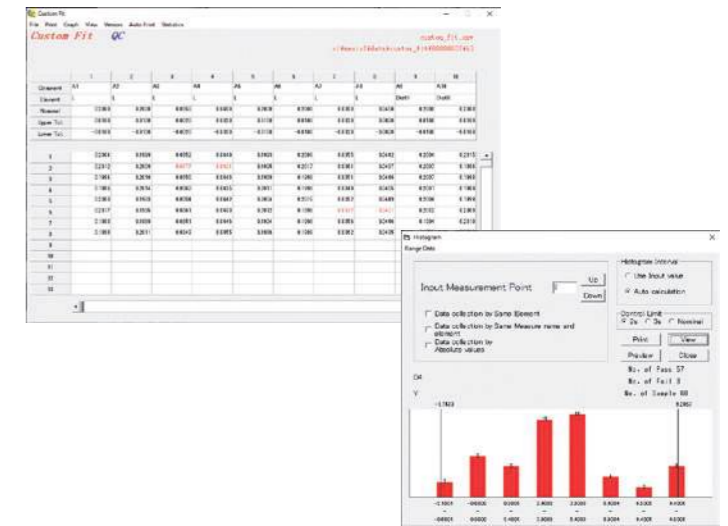

Custom Create: Direct link to Excel worksheets

Measurement data from counters and/or data processors can be transferred directly to Excel sheets. Multiple worksheets can be transferred at once, achieving efficient measurements.

- Compatible measuring instruments: MM-400N/800N series, DP-E1A, V-20B, V-12B
- Allows data transfer to customized inspection-result sheet forms
- 3 standard inspection result sheets are available

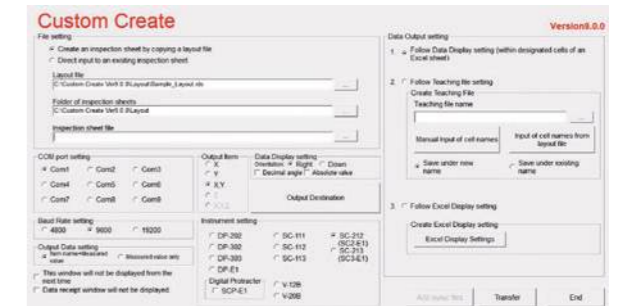

Operating environment:

- Windows®7 or Windows®10
- Microsoft Excel® 2003 or later
- Required memory: 512MB (min)
- Codevelopment: Aria Co., Ltd.

ACCESSORIES

Counters

3-Axis/2-Axis Counters

The display unit can be mounted on either side of the main body. Counters can be connected with data processors and digital printers via the RS-232C port.



3-axis counter

2-axis counter

XY Reset Switch

Can be attached to the main body to easily reset values while using the stage.



X/Y-axis

Counter Remote Switch

Enables remote control of the counter's RESET and SEND.



Digital Thermal Printer TSP743II

Connect to the MM-400N/800N control box to print out values from the counter.



TSP743II

Foot Switch

Used to send load command to DP-E1A. Frees both hands to enhance measurement efficiency.



Calibration Scale 300 mm

Used to calibrate feeding accuracy of stage up to 300 mm. The scale is made of low expansion glass to minimize thermal error. Both 10 mm-interval sensor patterns and calibrations are provided.

Accuracy: Within 1 μm against compensation values.



Vibration Isolation Table

Provides a stable, even surface by reducing floor vibrations. Compatible with measuring microscopes, data processing systems, external light modulators, and computers.

	MM-400N/800N
Installation part (WxD)	450(W)×689(D)mm
Dimensions (WxDxH)	1058(W)×689(D)×751(H)mm



Dimensional Diagram

MM-400N/M
PS 2x2B Stage

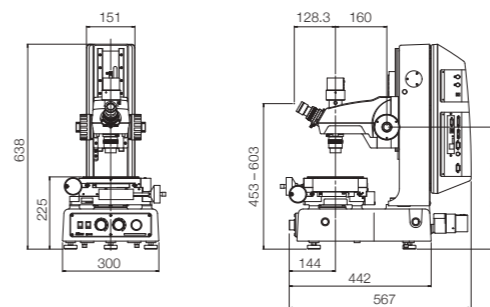

MM-800N/L
PS 10x6B Stage

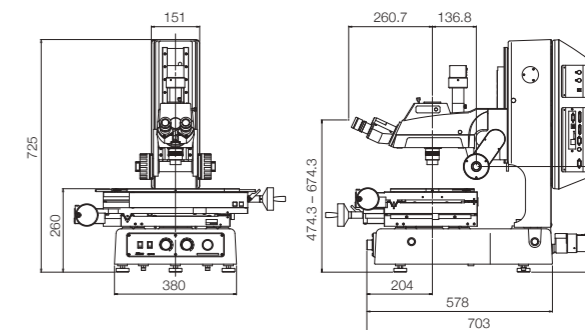

MM-400N/L
PS 4x4B Stage

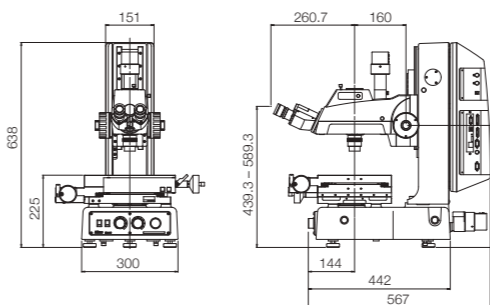

MM-800N/LM
PS 12x8C Stage

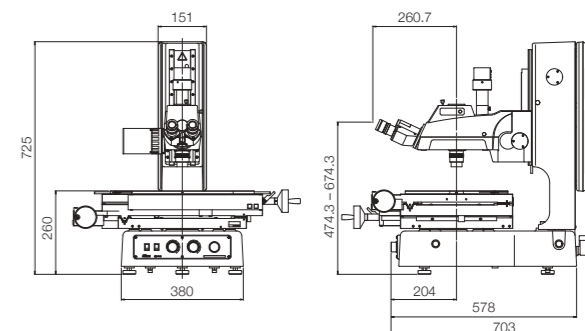

MM-400N/LV
PS 6x4B Stage

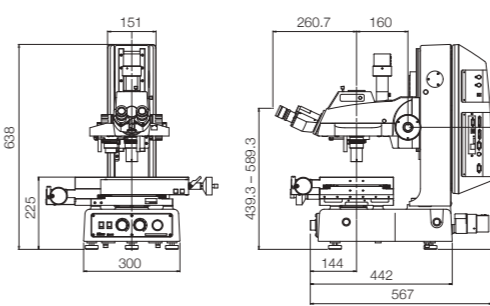

MM-800N/LU
PS 8x6B Stage

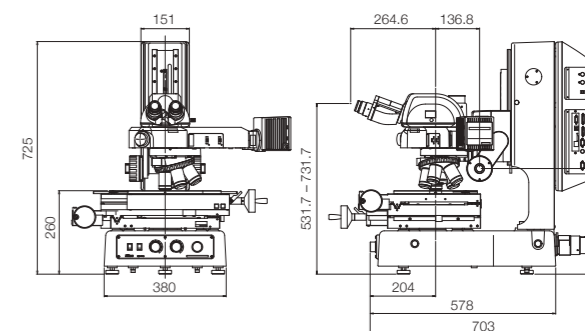

MM-400N/LUFA
PS 6x4B Stage

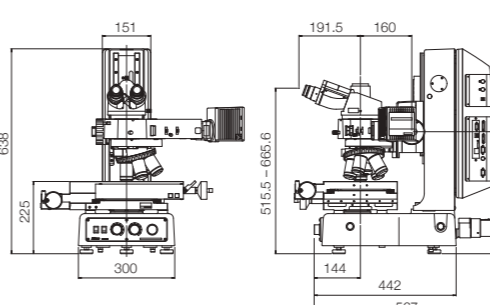

MM-800N/LMU
PS 12x8C Stage

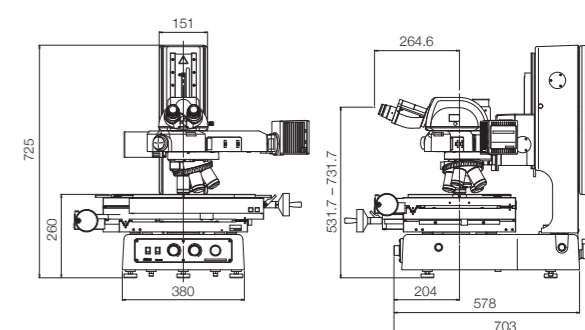

*Dimensions may vary depending on the combination of stage and optical head.

System Diagram (MM-Type)

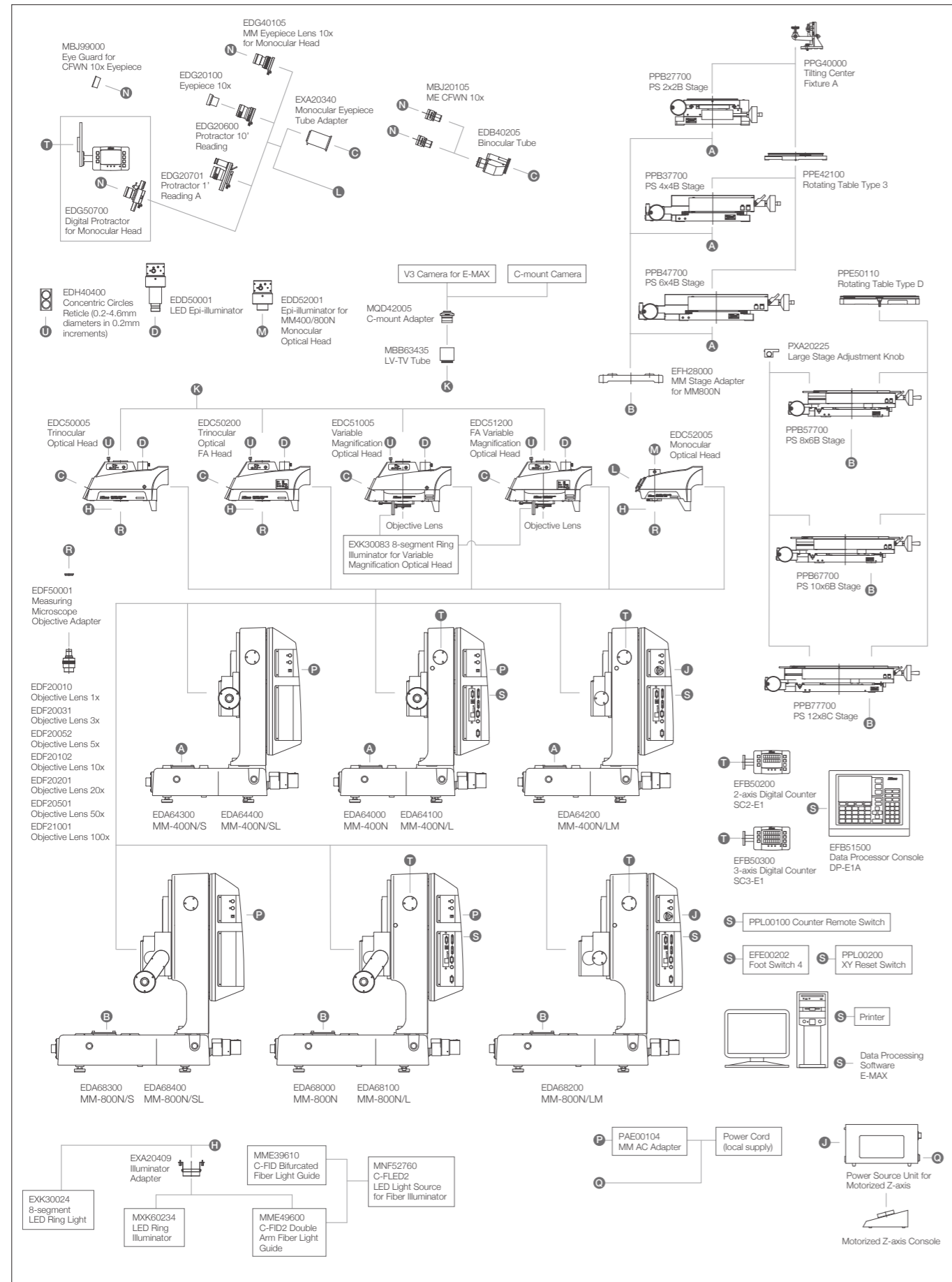

System Diagram (U-Type)

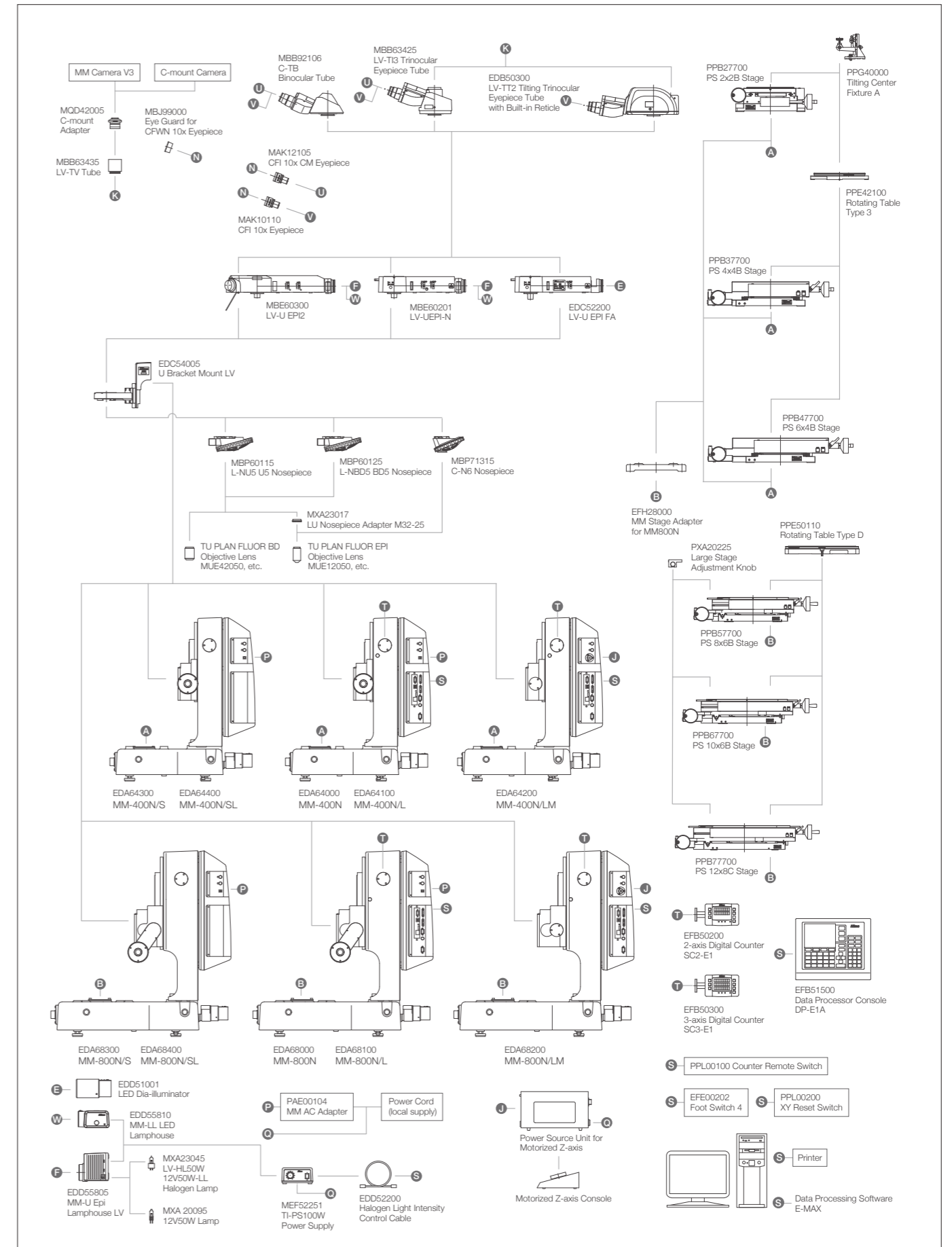

■ Suggested Configuration Chart

MM-Type

	Model	MM-400N/S	MM-400N	MM-400N/L	MM-400N/SL	MM-400N/LM	MM-800N/S	MM-800N	MM-800N/SL	MM-800N/L	MM-800N/LM
	Z-axis Motion	Manual	Manual	Manual	Manual	Motorized	Manual	Manual	Manual	Manual	Motorized
	Z-axis Scale	No	No	Yes	Yes	Yes	No	No	Yes	Yes	Yes
	MM Controller Backpack Interface	No	Yes	Yes	No	Yes	No	Yes	No	Yes	Yes
	Stage	PS 4x4B	PS 2x2B	PS 6x4B	PS 6x4B	PS 6x4B	PS 8x6B	PS 10x6B	PS 10x6B	PS 12x8C	PS 12x8C
	Head	Trinocular	Monocular	Trinocular	Trinocular	Trinocular	Trinocular	Trinocular	FA	Trinocular	FA
	Illuminators	-	-	Fiber Ring	-	8-seg. LED Ring	-	White LED Ring	-	8-seg. LED Ring	8-seg. LED Ring
Product Code	Data Processors	-	-	DP-E1A	-	E-MAX V3	-	DP-E1A	-	E-MAX V3	E-MAX V3
Main Body Stand	EDA64000	MM-400N Stand	✓								
	EDA64100	MM-400N/L Stand		✓							
	EDA64200	MM-400N/LM Stand					✓				
	EDA64300	MM-400N/S Stand	✓								
	EDA64400	MM-400N/SL Stand			✓						
	EDA68000	MM-800N Stand						✓			
	EDA68100	MM-800N/L Stand							✓		
	EDA68200	MM-800N/LM Stand								✓	✓
	EDA68400	MM-800N/SL Stand							✓		✓
	EDA68300	MM-800N/S Stand						✓			
PAE00104	MM AC Adapter	✓	✓	✓ 2pcs	✓	✓	✓ 2pcs	✓	✓	✓	
Local supply	Power Cable	✓	✓	✓ 2pcs	✓	✓	✓ 2pcs	✓	✓	✓	
Optical Head and Eyepiece Tube/Lenses Illuminators	EDC52005	Monocular Optical Head		✓							
	EDG40105	MM Eyepiece Lens 10x for Monocular Head		✓							
	EDC50005	Trinocular Optical Head	✓		✓	✓	✓	✓		✓	
	EDC50200	Trinocular Optical FA Head							✓		✓
	EDB40205	Binocular Tube	✓		✓	✓	✓	✓	✓	✓	✓
	MBJ20105	CFWN 10x Eyepiece (2pcs)	✓		✓	✓	✓	✓	✓	✓	✓
	EDD50001	LED Epi-Illuminator	✓		✓	✓	✓	✓	✓	✓	✓
	EDD52001	Epi-Illuminator for MM400N/800N Monocular Optical Head		✓							
	EXK30024	8-segment LED Ring Light (100-240V)					✓			✓	✓
	EXA20411	E-BUS Cable		✓			✓			✓	✓
	Local supply	Power Cable					✓			✓	✓
	EXA20409	Illuminator Adapter			✓				✓		
	MME39610	C-FIR Ring Fiber Illuminator Guide			✓						
	MNF52760	C-FLED2 LED Light Source for Fiber Illuminator			✓						
	MXK60234	LED Ring Illuminator (100-240V) (ESD Type only)							✓		
Objective Lenses	EDF20031	Objective Lens 3x	✓	✓	✓	✓	✓	✓	✓	✓	✓
	EDF20102	Objective Lens 10x							✓		✓
	EDF50001	Measuring Microscope Objective Adapter	✓	✓	✓	✓	✓	✓	✓ 2pcs	✓	✓ 2pcs
Stages and Rotating Tables	PPB27700	PS 2x2B Stage		✓							
	PPB37700	PS 4x4B Stage	✓								
	PPB47700	PS 6x4B Stage			✓	✓					
	PPB57700	PS 8x6B Stage					✓				
	PPB67700	PS 10x6B Stage						✓			
	PPB77700	PS 12x8C Stage							✓		✓
	EFH28000	MM Stage Adapter for MM800 (PS 6x4B or smaller)									
	PXA20225	Large Stage Adjustment Knob					✓	✓	✓	✓	✓
	PPE42100	Rotating Table Type 3			✓	✓	✓				
	PPE50110	Rotating Table Type 4					✓	✓	✓		
Data Processing System and Printer	EFB50200	2-axis Digital Counter SC2-E1		✓							
	EFB50300	3-axis Digital Counter SC3-E1			✓		✓			✓	✓
	EFB51500	Data Processor Console DP-E1A			✓		✓				
	PXA20218	SC-213 Z-signal Cable				✓			✓		
	PPL00200	XY Reset Switch		✓							
	EFE00202	Foot Switch 4			✓				✓		✓
	EXK30330	Thermal Printer Model TSP743 II			✓				✓		
	EXA20478	9-25 Pins RS-232C Cross Cable (2 m)			✓				✓		
	EXK30105	Printer Paper			✓				✓		
	Local supply	Power Cable			✓				✓		
	EDF11000	Data Processing Software E-MAX								✓	✓
	EXA20371	E-MAX Calibration Plate					✓			✓	✓
	EDE50100	MM Camera V3					✓			✓	✓
	EDE50110	MM Camera V3 Cable					✓			✓	✓
	MBB63435	LV-TV Tube					✓			✓	✓
MQD42005	C-mount Adapter					✓			✓	✓	

• MM Cable for Simultaneous Use (PXA20224) is required for simultaneous use of Foot Switch and [RESET/SEND] buttons.

U-Type

	Model	MM-400N/U	MM-400N/LU	MM-400N/LMU	MM-800N/SU	MM-800N/LU	MM-800N/SLU	MM-800N/LMU	MM-800N/LMU	MM-800N/SLU
	Z-axis Motion	Manual	Manual	Motorized	Manual	Manual	Manual	Motorized	Manual	Manual
	Z-axis Scale	No	Yes	Yes	No	Yes	Yes	Yes	Yes	No
	MM Controller Backpack Interface	Yes	Yes	Yes	No	Yes	No	Yes	Yes	No
	Stage	PS 4x4B	PS 4x4B	PS 6x4B	PS 6x6B	PS 12x8C	PS 10x6B	PS 12x8C	PS 12x8C	PS 10x6B
	Head	C-TB	TT2	TT3	TT3	TT2	TT2	TT2	TT2	TT3
	Illuminator	LV-EPI LED	LV-U EPI FA	LV-U EPI2	LV-U EPI	LV-U EPI FA	LV-U EPI FA	LV-U EPI2	LV-U EPI2	LV-U EPI FA
	Illuminators	-	E-MAX V3	E-MAX V3	-	E-MAX V3	-	E-MAX V3	E-MAX V3	-
Product Code	Data Processors	BF	BD-DIC	BD-DIC-FL	BF	BD-DIC	BD	BD-DIC	BD-DIC-FL	BF
Main Body Stand, U-bracket and Illuminator	EDA64000	MM-400N Stand	✓							
	EDA64100	MM-400N/L Stand		✓						
	EDA64200	MM-400N/LM Stand					✓			
	EDA64400	MM-400N/SL Stand								
	EDA68000	MM-800N Stand								
	EDA68100	MM-800N/L Stand								✓
	EDA68200	MM-800N/LM Stand							✓	✓
	EDA68400	MM-800N/SL Stand							✓	✓
	EDA68300	MM-800N/S Stand							✓	✓
	PAE00104	MM AC Adapter	✓	✓		✓	✓	✓	✓	✓
Local supply	Power Cable	✓	✓	✓	✓	✓	✓	✓	✓	
EDC54005	U Bracket Mount LV	✓	✓	✓	✓	✓	✓	✓	✓	
Stages and Rotating Tables	PPB37700	PS 4x4B Stage	✓	✓						
	PPB47700	PS 6x4B Stage			✓					
	PPB57700	PS 8x6B Stage					✓			
	PPB67700	PS 10x6B Stage						✓		✓
	PPB77700	PS 12x8C Stage							✓	✓
	EFH28000	MM Stage Adapter for MM800 (PS 6x4B or smaller)							✓	✓
	PXA20225	Large Stage Adjustment Knob							✓	✓
	PPE42100	Rotating Table Type 3							✓	✓
	PPE50110	Rotating Table Type 4							✓	✓
	EFE00202	Foot Switch 4							✓	✓
Data Processing System and Printer	EDF11000	Data Processing Software E-MAX							✓	✓
	EXA20371	E-MAX Calibration Plate							✓	✓
	EDE50100	MM Camera V3							✓	✓
	EDE50110	MM Camera V3 Cable							✓	✓
	MBB63435	LV-TV Tube							✓	✓
	MQD42005	C-mount Adapter							✓	✓
	EFB50200	2-axis Digital Counter SC2-E1		✓						
	EFB50300	3-axis Digital Counter SC3-E1			✓		✓		✓	✓
	EFB51500	Data Processor Console DP-E1A			✓		✓			
	PXA20218	SC-213 Z-signal Cable				✓			✓	
U-Epi Illuminators	MBE60201	LV-U EPI (BF DF DIC)				✓				
	EDC52200	LV-U EPI FA					✓	✓	✓	✓
	EDD51001	LED Dia-Illuminator (used for U-FA as Epi-Illuminator)					✓		✓	✓
	MBE60300	LV-U EPI2 (BF DF DIC FL)							✓	✓
	MBN66750	YM-NCB25 NCB11					✓		✓	✓
	MBN66760	YM-ND25 ND4/ND16					✓		✓	✓
	EDD55805	MM-U Epi Lamphouse LV					✓		✓	✓
	EDD55810	MM-LL LED Lamphouse					✓		✓	✓
	MEF52251	TI-PS100W Power Supply (100-240V)					✓		✓	✓
	Local supply	Power Cable							✓	✓
Filters and Light Sources	MBB92106	C-TB Binocular Tube	✓							
	MBB63425	LV-TI3 Trinocular Eyepiece Tube			✓ 2pcs		✓			✓
	EDB50300	LV-TT2 Trinocular Tube with Built-in Reticle			✓			✓		✓
	MAK10110	CFI 10x Eyepiece	✓			✓			✓	✓
	MAK12105	CFI 10x CM Eyepiece with Crosshairs	✓			✓			✓	✓
	MBP60115	L-NU5 U5 Nosepiece ESD				✓			✓	✓
	MBP60125	L-NBD5 BD5 Nosepiece							✓	✓
	MBP71316	C-N6 Nosepiece (up to 5 objective lenses)	✓							✓
	MUE12050	TU PLAN FLUOR EPI 5x	✓				✓			✓
	MUE12100	TU PLAN FLUOR EPI 10x	✓				✓			✓
Relieving Nosepiece	MUE21200	TU PLAN EPI ELWD 20xA	✓						✓	✓
	MUE21500	TU PLAN EPI ELWD 50xA	✓						✓	✓
	MUE42050	TU PLAN FLUOR BD 5x				✓		✓	✓	✓
	MUE42100	TU PLAN FLUOR BD 10x				✓		✓	✓	✓
	MUE61200	TU PLAN BD ELWD 20x				✓		✓	✓	✓
	MUE61500	TU PLAN BD ELWD 50x				✓		✓	✓	✓
	MUE61900	TU PLAN BD ELWD 100x				✓		✓	✓	✓
	MBP60170	L2-DIC Prism for Eclipse Microscopes					✓		✓	✓
	MBN66923	LV-PO Polarizer for LV-U EPI2 (MBE60200)					✓		✓	✓
	MBN66922	L-AN Analyzer for LV-U EPI2 (MBE60200)					✓		✓	✓
Objective Lenses and Accessories	MBN66921	YM-PO Polarizer for LV-U EPI FA (EDC52200)							✓	✓

LED Episcopic & Diascopic Illuminator is a Class 1 LED Product

CLASS 1 LED PRODUCT

8-segment LED Ring Light is a Class 2 LED Product

**CAUTION – CLASS 2 LED RADIATION
DO NOT STARE INTO THE BEAM**

ISO/IEC 17025 Certified

Nikon Corporation Industrial Solutions Business Unit is certified as an ISO/IEC 17025 accredited calibration laboratory for measuring microscopes and measuring projectors (profile projectors) by the Japan Accreditation Board for Conformity Assessment.

(ISO/IEC 17025: International standard, which specifies the general requirements to ensure that a laboratory is competent to carry out specific tests and/or calibrations)

Date of Initial accreditation:	September 8, 2006
Scope of accreditation:	Measuring microscopes
Accredited section:	Industrial Solutions Business Unit
Calibration site:	Customer's laboratory (field service)
Expanded Uncertainty:	X/Y-axis indication accuracy of measuring microscopes Linear scale up to 300 mm: $(0.70 + 5.0 \times 10^{-3} \times L) \mu\text{m}$

Specifications and equipment are subject to change without any notice or obligation on the part of the manufacturer. September 2024 ©2006-2024 NIKON CORPORATION

N.B. Export of the products* in this brochure is controlled under the Japanese Foreign Exchange and Foreign Trade Law. Appropriate export procedures shall be required in case of export from Japan.

*Products: Hardware and its technical information (including software)



WARNING TO ENSURE CORRECT USAGE, READ THE CORRESPONDING MANUALS CAREFULLY BEFORE USING THE EQUIPMENT.



NIKON CORPORATION

1-5-20, Nishiio, Shinagawa-ku, Tokyo 140-8601, Japan
phone: +81-3-6743-5742 fax: +81-3-6410-7252
<https://industry.nikon.com/>

ISO 14001 Certified
for NIKON CORPORATION

ISO 9001 Certified
for NIKON CORPORATION
Industrial Solutions Business Unit

NIKON METROLOGY EUROPE NV

Interleuvenlaan 86 B-3001 Leuven, Belgium
phone: +32-16-74-01-00 fax: +32-16-74-01-03
E-mail: Sales.Europe.NM@nikon.com
<https://industry.nikon.com/en-gb/>

NIKON METROLOGY UK LTD.

UNITED KINGDOM phone: +44-1332-811-349 fax: +44-1332-639-881
E-mail: Sales.UK.NM@nikon.com

NIKON METROLOGY SARL

FRANCE phone: +33-1-60-86-09-76 fax: +33-1-60-86-57-35
E-mail: Sales.France.NM@nikon.com

NIKON METROLOGY GMBH

GERMANY phone: +49-211-45-44-69-51
E-mail: Sales.Germany.NM@nikon.com

NIKON INSTRUMENTS S.p.A.

ITALY phone: +39-055-300-96-01 fax: +39-055-30-09-93

NIKON METROLOGY, INC.

12701 Grand River Road, Brighton, MI 48116 U.S.A.
phone: +1-810-220-4360 fax: +1-810-220-4300
E-mail: Sales.NM-US@nikon.com
<https://industry.nikon.com/en-us/>

NIKON METROLOGY - MÉXICO

E-mail: Sales.NM-MX@nikon.com

NIKON PRECISION (SHANGHAI) CO., LTD.

CHINA (Shanghai branch) phone: +86-21-6841-2050 fax: +86-21-6841-2060
(Beijing branch) phone: +86-10-5831-2028 fax: +86-10-5831-2026
(Guangzhou branch) phone: +86-20-3882-0511 fax: +86-20-3882-0580

NIKON INSTRUMENTS KOREA CO., LTD.

KOREA phone: +82-2-6288-1900 fax: +82-2-555-4415

NIKON SINGAPORE PTE. LTD.

SINGAPORE phone: +65-6559-3651 fax: +65-6559-3668
E-mail: NSG.Industrial-sales@nikon.com

PT. NIKON INDONESIA

INDONESIA phone: +62-213-873-5005 fax: +62-213-873-5006

E-mail: PTN.Instruments@nikon.com

NIKON SALES (THAILAND) CO., LTD.

THAILAND phone: +66-2633-5100 fax: 66-2633-5191



Printed in Japan (2409) Am/M

Code No. 2CE-I0GH-5

RYF AG

RYF AG
Betlachstrasse 2
CH-2540 Grenchen
Tel +41 32 654 21 00

www.ryfag.ch

RYF SA Succursale
Route de Genève 9c
CH-1291 Commugny
Tel +41 22 776 82 28

ryfag@ryfag.ch

RYF AG (Zürich)
Im Hanselmaa 10
CH-8132 Egg / Uster/ZH
Tel +41 43 277 59 99

CHE-106.926.853 MWST
SWIFT-Code RSOCH22
IBAN-Nr. CH80 0878 5016 0009 9850 6

